



230 V AC

- 1-channel
- Control circuit EEx ia IIC
- Reversible mode of operation
- 1 relay output with 1 changeover contact
- EMC acc. to NAMUR NE 21
- LB/SC monitoring
- Usable up to SIL 2 acc. to IEC 61508

Function

The transformer isolated barrier transfers digital signals from the hazardous area. Sensors per DIN EN 60947-5-6 (NAMUR) and mechanical contacts may be used as alarms. Control circuits are monitored for lead breakage (LB) and short circuit (SC). The external faults are indicated according to NAMUR NE44 by a red flashing LED. For type KFD2-SR2-Ex1.W, an LB/SC collective error message is in addition transferred through the Power Rail to the power feed module. The intrinsically safe input is per DIN EN 50020 safely isolated from the output and the power supply. The relay output is in accordance with IEC 61140 safely isolated from the power supply.

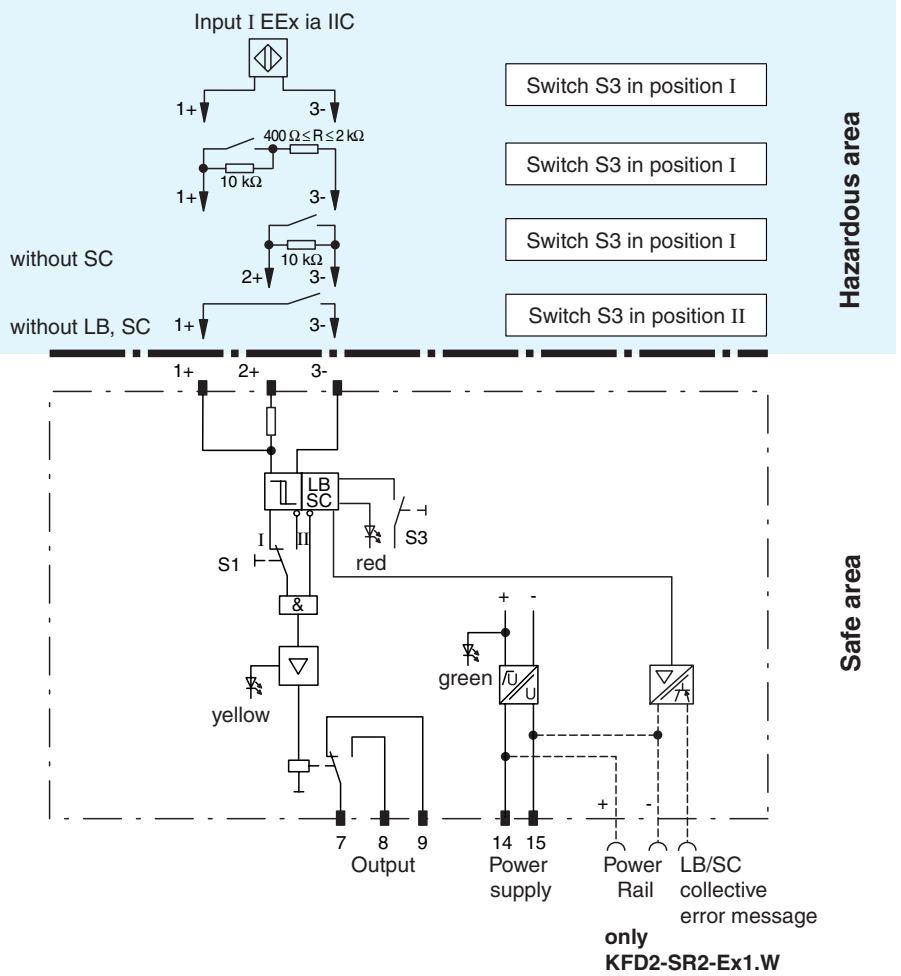

Composition

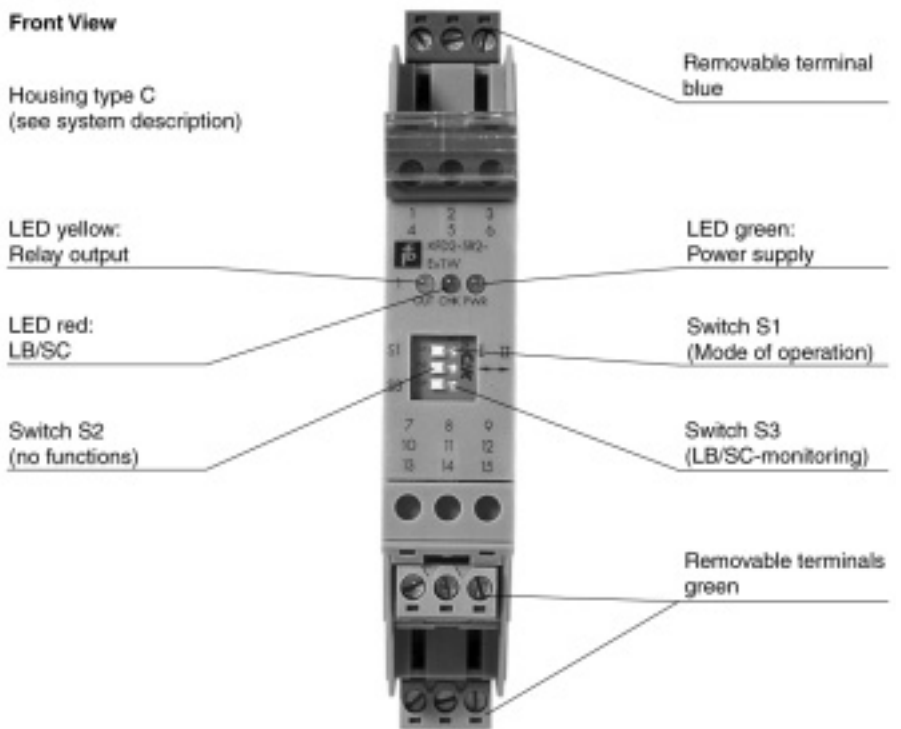

Supply	
Connection	terminals 14, 15
Rated voltage	207 ... 253 V AC, 45 ... 65 Hz
Ripple	-
Rated current	-
Power loss	1 W
Power consumption	≤ 1 W
Input	
Connection	terminals 1+, 2+, 3-
Rated values	acc. to IEC 60947-5-6 (NAMUR, DIN 19234), see system description for electrical data
Open circuit voltage/Short-circuit current	approx. 8 V DC / approx. 8 mA
Switching point/Switching hysteresis	1,2 ... 2,1 mA / approx. 0,2 mA
Pulse / Pause ratio	≥ 20 ms / ≥ 20 ms
Lead monitoring	breakage I ≤ 0,1 mA , short-circuit I > 6 mA
Output	
Connection	terminals 7, 8, 9
Output	signal ; relay
Contact loading	253 V AC / 2 A / cos φ > 0.7; 126.5 V AC / 4 A / cos φ > 0.7; 40 V DC / 2 A resistive load
Energised/De-energised delay	approx. 20 ms / approx. 20 ms
Mechanical life	10 ⁷ switching cycles
Transfer characteristics	
Switching frequency	< 10 Hz
Electrical isolation	
Output/Power supply	reinforced insulation according to IEC 61140, rated insulation voltage 300 V _{eff}
Standard conformity	
Climatic conditions	acc. to DIN IEC 721
Directive conformity	
Electromagnetic compatibility	standards
Directive 89/336/EG	EN 61326, EN 50081-2, NE 21
Ambient conditions	
Ambient temperature	-20 ... 60 °C (253 ... 333 K)
Mechanical specifications	
Protection degree	IP20
Mass	approx. 150 g
Data for application in conjunction with hazardous areas	
EC-Type Examination Certificate	PTB 00 ATEX 2081 , for additional certificates see www.pepperl-fuchs.com
Group, category, type of protection	⊕ II (1) G D [Ex ia] IIC [circuit(s) in zone 0/1/2]
Input	Ex ia IIC
Voltage U ₀	10,6 V
Current I ₀	19,1 mA
Power P ₀	51 mW (linear characteristic)
Type of protection [Ex ia and Ex ib]	
Explosion group	IIA IIB IIC
External capacitance	72 μF 16,2 μF 2,32 μF
External inductance	780 H 390 mH 97 mH
Supply	
Safety maximum voltage U _m	253 V AC / 126,5 V AC (Attention! U _m is no rated voltage.)
Output	
Contact loading	253 V AC / 2 A / cos φ > 0.7; 126.5 V AC / 4 A / cos φ > 0.7; 40 V DC / 2 A resistive load
Safety maximum voltage U _m	253 V AC (Attention! The rated voltage can be lower)
Electrical isolation	
Input/Output	safe electrical isolation acc. to EN 50020, voltage peak value 375 V
Input/Power supply	safe electrical isolation acc. to EN 50020, voltage peak value 375 V
Directive conformity	
Directive 94/9 EU	EN 50014, EN 50020
Entity parameter	
Certification number	J.I.3002773
FM control drawing	No. 116-0035
Suitable for installation in division 2	yes
Connection	terminals 1, 3; 2, 3; 4, 6; 5, 6
Input I	
Voltage V _{OC}	12,9 V
Current I _t	19,8 mA
Explosion group	A&B C&E D, F&G

Max. external capacitance C_a	1,273 μ F	3,82 μ F	10,18 μ F
Max. external inductance L_a	84,8 mH	254,4 mH	678,4 mH
Safety parameter			
UL control drawing	E 106378		
CSA control drawing	LR 36087-19		
Control drawing	No. 116-0047		
Connection	terminals 1, 3; 2, 3; 4, 6; 5, 6		
Input I			
Safety parameter	12,6 V / 650 Ohm		
Voltage V_{OC}	12,9 V		
Current I_{SC}	19,8 mA		
Explosion group	A&B	C&E	D, F&G
Max. external capacitance C_a	1,273 μ F	3,82 μ F	10,18 μ F
Max. external inductance L_a	84,88 mH	298,7 mH	744,4 mH

Supplementary information

EC-Type Examination Certificate, Statement of Conformity, Declaration of Conformity and instructions have to be observed. This information can be found under www.pepperl-fuchs.com