

## Product Information

### VEGACOM 557 interface converter

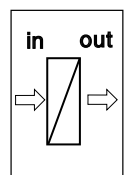
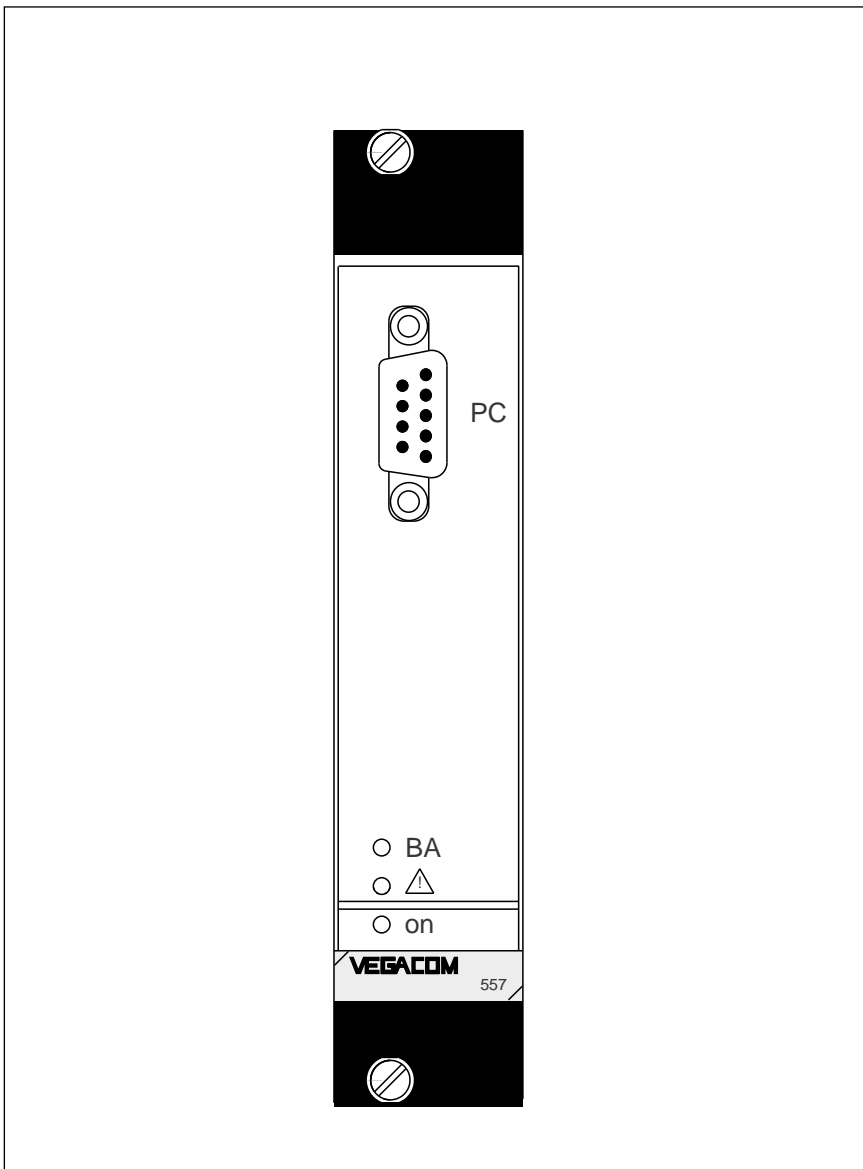

**Contents**

|     |   |    |
|-----|---|----|
| 1   | Product description .....   | 3  |
| 2   | Function and application  |    |
| 2.1 | Functional principle .....  | 4  |
| 2.2 | Function course .....   | 4  |
| 2.3 | Adjustment .....  | 4  |
| 2.4 | Configuration and parameter adjustment of connected measuring systems ..... | 5  |
| 2.5 | Visualization .....   | 5  |
| 2.6 | Measuring system with digital communication .....                           | 6  |
| 3   | Types and versions  |    |
| 3.1 | ASCII-Code .....  | 7  |
| 3.2 | Interbus S .....  | 7  |
| 3.3 | Modbus .....  | 8  |
| 3.4 | Profibus DP .....   | 8  |
| 3.5 | Profibus FMS .....  | 9  |
| 3.6 | Siemens 3964 and 3964 R-Procedure .....                                     | 10 |
| 3.7 | Technical data and dimensions .....   | 11 |
| 4   | Mounting and installation   |    |
| 4.1 | Mounting and connection instructions .....                                  | 15 |
| 4.2 | Mounting into carrier and housing .....                                     | 15 |
| 5   | Electrical connection   |    |
| 5.1 | Connection instructions .....   | 16 |
| 5.2 | Connection plans .....  | 16 |
| 6   | Order code .....  | 18 |

# 1 Product description

VEGACOM 557 is an efficient interface converter (Gateway). It is used for conversions of VEGA-specific DISBUS and LOGBUS-protocols into standard data formats. In this way measuring data and status information of level and pressure measuring systems can be transferred to subordinate automation system and visualized there or processed for control purposes.

The coupling between VEGACOM 557 and the automation system is made acc. to the protocol as point-to-point connection or via a bus technology. The following versions are available:

- ASCII
- Interbus S
- Modbus
- Siemens 3964 and 3964 R
- Profibus DP
- Profibus FMS

The gateway concept ensures the integration of measuring data into existing control systems. By using a VEGACOM 557 interface converter, already connected systems can be realized which suit the future requirements. For adaption to a new protocol, proven sensors and signal conditioning instruments must not be modified but only the interface converter must be exchanged.

VEGACOM 557 is designed as component in 19"-technology with 5 TE-width (1 TE = 5,08 mm) acc. to DIN 41 494. It can be used:

- in carrier BGT 596
- in VEGALOG carrier BGT LOG 571
- in housing type 505.

The electrical connection is made via a plug acc. to DIN 41 612 on the rear of the component. The connection to LOGBUS is made via an additional 5-pole plug connector, mounted on the DIN-plug connector.

In the front plate of VEGACOM 557 is located a 9-pole D-SUB-plug. It is used for connection of a PC via RS 232 C to VEGACOM 557.

The component consists of two boards:

- the basic board
- the additional board.

The power supply unit, the PC RS 232 C-interface as well as the DISBUS/LOGBUS-interface are located on the basic board.

The additional board is screwed to the basic board and includes the microcontroller as well as the respective interface to the automation system.

### User advantages

- Unique interface for visualization and adjustment at VEGAMET and VEGALOG
- Coupling to automation systems via standard Fieldbus-protocols
- Future connectability: Sensors and signal conditioning instruments remain even when the Fieldbus-protocol is modified
- Digital communication from the sensor via signal conditioning instrument and indication to the DCS/PLC

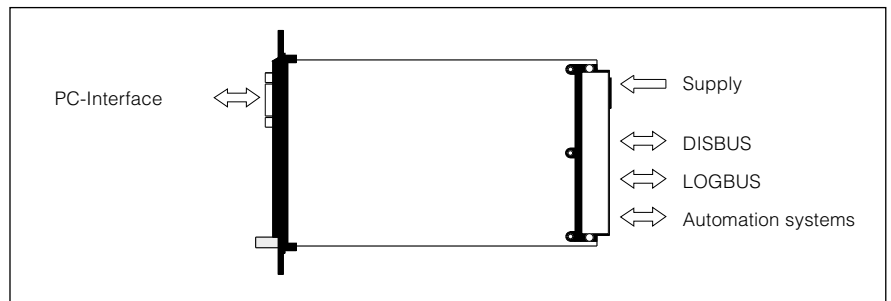

Fig. 1.1 Connections of VEGACOM 557

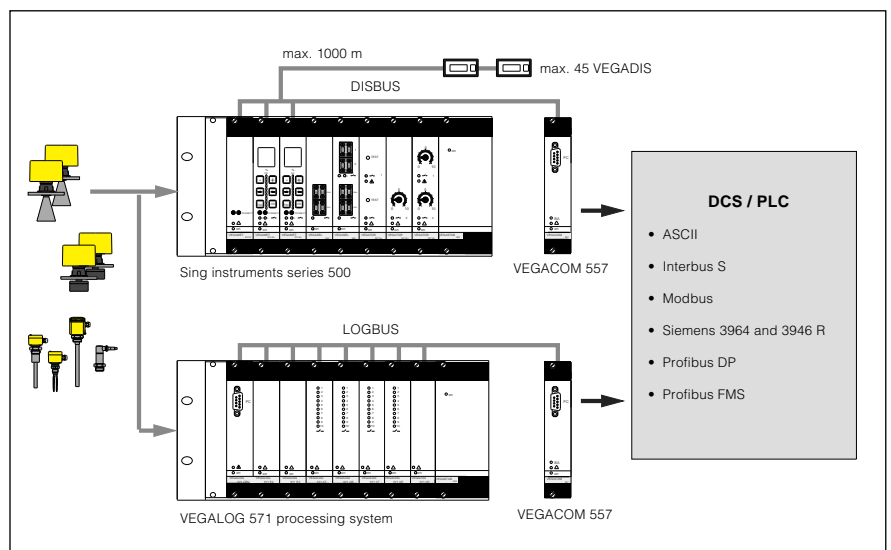

Fig. 1.2 VEGACOM 557 gateway is the junction between measuring systems and automation systems

## 2 Function and application

### 2.1 Functional principle

VEGACOM 557 gateway can be integrated in two ways into level and pressure measuring systems:

- as DISBUS-participant
- as LOGBUS-participant.

In both cases it is a passive participant and must not be addressed.

#### VEGACOM 557 as DISBUS-participant

VEGAMET series 500 signal conditioning instruments transmit via DISBUS measuring data and status information to VEGADIS 174 indicating instruments. VEGACOM 557 receives as participant on the DISBUS these data in a DCS-telegram. The telegrams are written in a buffer memory of VEGALOG 557.

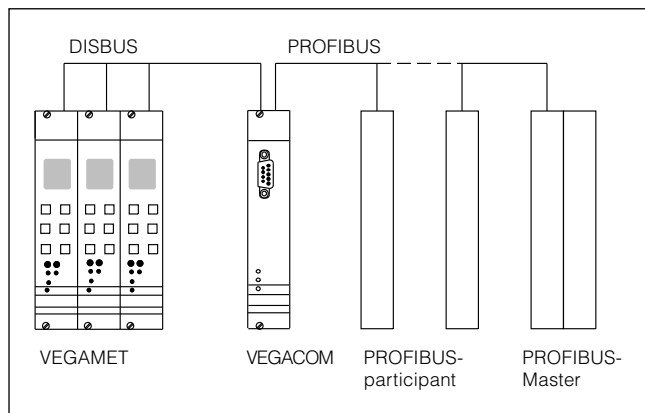

Fig. 2.1 Example for VEGACOM 557 as Gateway between DISBUS and Profibus

#### VEGACOM 557 as LOGBUS-participant

On the LOGBUS data are permanently exchanged between the individual components of VEGALOG 571. VEGACOM 557 receives as participant of this LOGBUS that part of the LOGBUS-telegrams, including the measured values and status information.

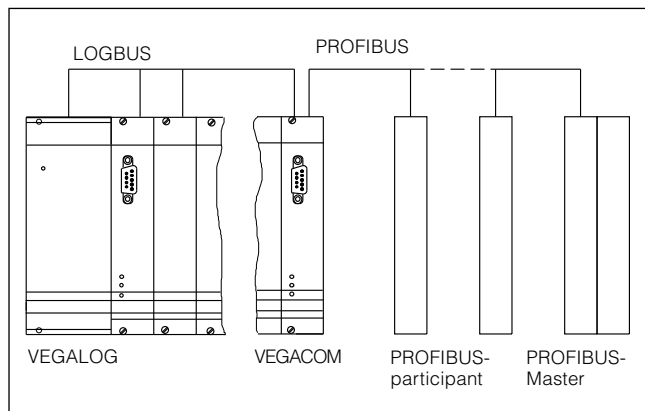

Fig. 2.2 Example for VEGACOM 557 as Gateway between LOGBUS and Profibus

### 2.2 Function course

The data from DISBUS or LOGBUS are first written in a buffer memory in VEGACOM 557.

The buffer memory transfers the data set into a process picture. The protocol converter software enquires cyclically the individual memory ranges on the stored values. The data sets are checked and converted into the respective standard data format. After this conversion the data are transmitted to the emission memory and transferred to the Profibus. The Profibus transmits the data to the automation system which accepts the data via a special component (e.g. communication processor or interface module).

The data communication between VEGACOM 557 and the automation system is initiated by the automation system requesting the desired information via special commands.

### 2.3 Adjustment

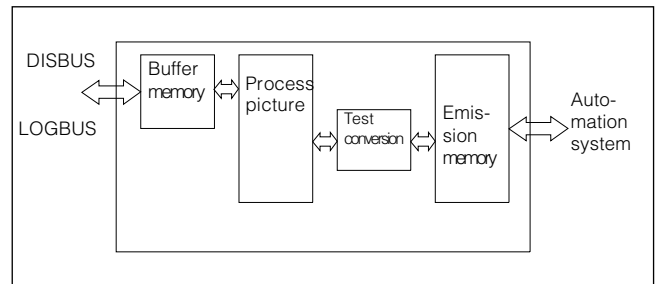

Fig. 2.3 Function of VEGACOM 557

The indicating elements of VEGACOM 557 are located in the front plate of the component. LEDs are used as indication elements which signal the operating condition. The operating elements are located on the boards.

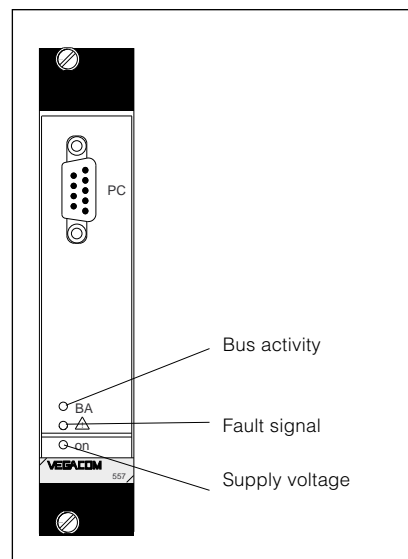

Fig. 2.4 Indicating elements in the front plate

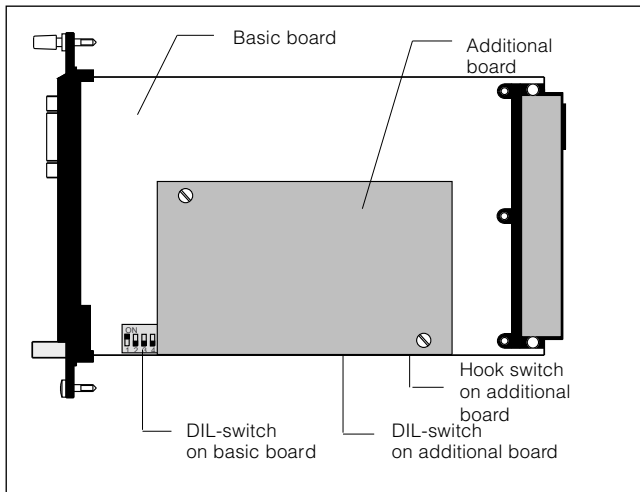

Fig. 2.5 Operating elements on the boards

A 6-pole DIL-switch block on the basic board is used for adjustment of the PC-interface. On the additional board are located acc. to the version 8-pole DIL-switch blocks as well as two hook switches.

Via the DIL-switches the specific parameters of the bus communication are adjusted, e.g. bus address and data communication rate; the hook switches are used for termination of the bus connection.

## 2.4 Configuration and parameter adjustment of connected measuring systems

An additional function of VEGACOM 557 is the adjustment of the connected measuring system. The adjustment is made via a PC by means of VEGA Visual Operating (VVO) operating software. The PC is connected via a RS 232-cable to the 9-pole D-SUB-plug in the front plate of VEGACOM 557 .

The VEGA-operating concept includes the easy configuration or parameter adjustment of the measuring system or the sensors of the following instruments:

- VEGAMET series 500 signal conditioning instruments
- VEGALOG 571 processing system
- Hydrostatic pressure transmitters
- Ultrasonic/radar sensors.

The operation is menu-guided and window oriented. No matter whether a radar sensor, several connected signal conditioning instruments or a VEGALOG should be operated via PC, the procedure is always the same.

The configuration of the measuring system comprises, acc. to the connected instruments, e.g. providing of addresses for bus communication, determination of processing functions or configuration of individual outputs. The application oriented adjustment of measuring points is supported by graphic means such as e.g. vessel drawings and pictographs which adapt acc. to the enquiry of the present frame conditions and options.

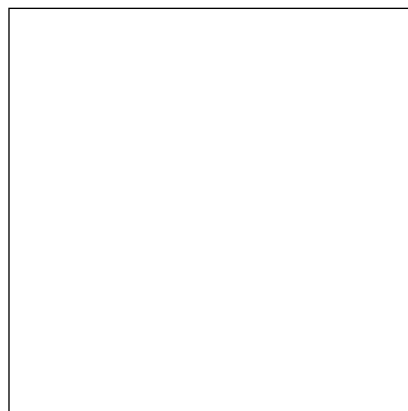

Fig. 2.6 Application oriented adjustment of a new measuring point

Due to the graphic support more complex parameter adjustments such as for example the adjustment of a linearization curve can be adjusted easily and clearly by means of index markers.

## 2.5 Visualization

The measured values of the VEGA-processing systems can be demonstrated graphically or in tabular form by means of the visualization program Visual VEGA (VV).

Measured value and status information are transmitted via the RS 232-interface of VEGACOM 557 or the VEGALOG CPU-card to the PC. For better survey these measuring points can be composed to groups. Direct comparisons of several measuring points are therefore possible. In addition level and fault signals are indicated.

The measured values can be also saved on PC. The cycle and the memory period can be adjusted according to the requirement. The history data can be either demonstrated in tabular or in graphic form. The data conversion into ASCII-format ensures the data exchange with other programs.

## 2.6 Measuring system with digital communication

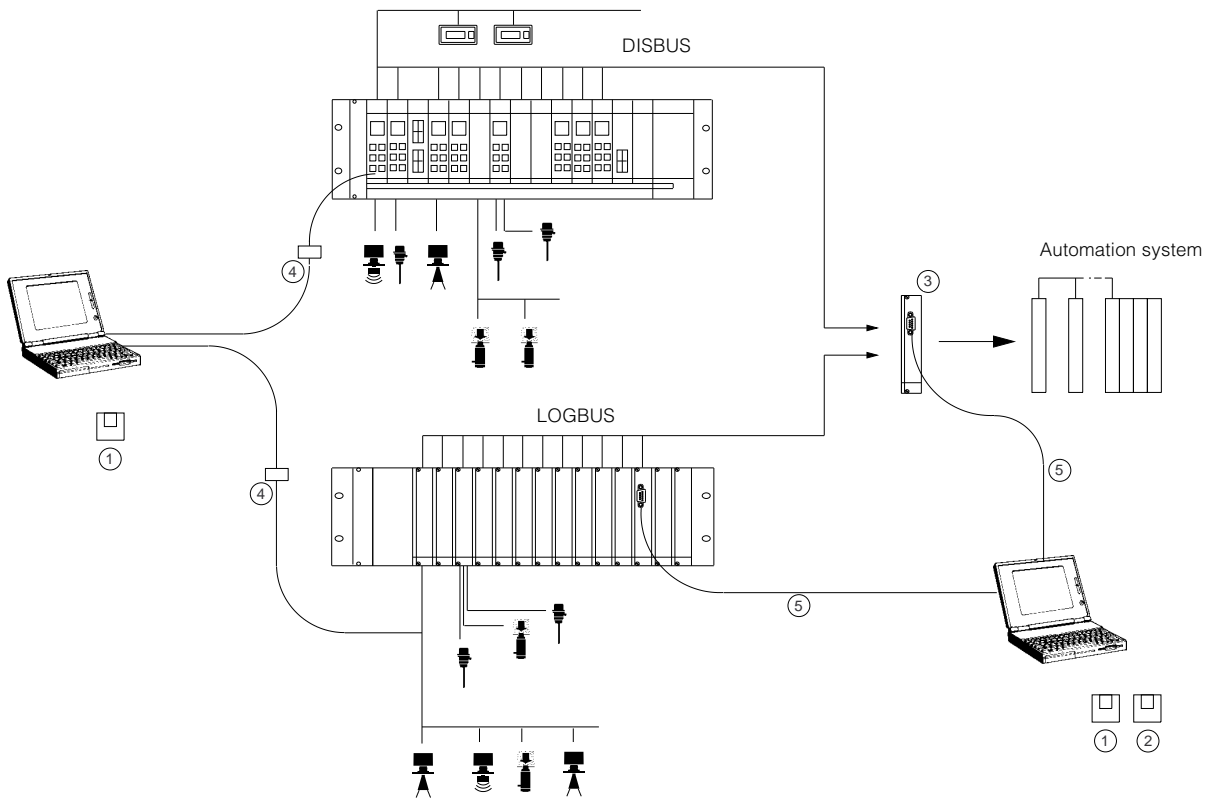

Fig. 2.7 Measuring system with digital communication and connectivity

### Explanation:

- |  |   |  |
|--|---|--|
| <p>1 VEGA Visual Operating (VVO) operating software for the PC for easy configuration and parameter adjustment of VEGA-instruments</p> <ul style="list-style-type: none"> <li>- VEGALOG 571 directly via RS 232-connection cable to CPU-card or VEGACOM 557</li> <li>- several VEGAMET via VEGACOM 557 or individually via VEGACONNECT</li> <li>- VEGASON, VEGAPULS via VEGACONNECT to the signal line or on the sensor</li> </ul> | <p>2 Visual VEGA (VV) Visualization software for the PC for graphic and tabular demonstration of measured values of VEGA-instruments. Composition of individual measuring points into groups, storing of fault signals and measured values (recording function). Connectivity via Windows for Workgroups.</p> <p>3 VEGACOM 557 Interface converter for conversion of VEGA-specific protocols into standard data formats. Suitable for connection to the DISBUS-output of VEGAMET series 500 signal conditioning instruments or the LOGBUS of the VEGALOG 571 processing system.</p> | <p>4 VEGACONNECT Connection cable (interface converter) between VEGA-instruments (VEGASON, VEGAPULS or VEGAMET) and a PC in conjunction with the VEGA Visual Operating software.</p> <p>5 RS 232-connection cable Connection cable between PC and VEGALOG 571-CPU or VEGACOM 557</p> |
|--|---|--|

### 3 Types and versions

#### 3.1 ASCII-Code

VEGACOM 557 ASCII-Code version ensures the coupling of measuring systems e.g. with IBM-compatible PCs. The connection can be either made as point-to-point connection via the RS 232-interface or as bus connection via the RS 485-interface of VEGACOM 557.

The data received by the PC can be visualized or processed by appropriate user programs.

If VEGACOM 557 is connected to a DISBUS, the PC must first of all send a requirement telegram of 5 byte length:

- 1 byte identifier for DCS-values or switching condition relay
- 1 byte address VEGACOM
- 2 byte address VEGAMET
- 1 byte end determination.

In the answer telegram of VEGACOM 557 the address of VEGACOM and VEGAMET as well as sequentially the DCS-values or status/failure information as ASCII-signs are provided.

When connected to the LOGBUS the PC must also provide a requirement telegram of 5 byte length:

- 1 byte identifier for DCS-values
- 3 byte number of the requested function component
- 1 byte end determination.

In the answering telegram VEGACOM 557 emits the function component number as well as the DCS-value or status/failure information as ASCII-sign.

#### 3.2 Interbus S

VEGACOM 557 in the Interbus S version enables the coupling of level and pressure measuring systems with the Interbus S-Fieldbus acc. to DIN 19 258 (standard sample).

An Interbus S-system in its topology is designed as a ring: each participant receives on its input data and sends them at the output to the next participant. Bus-participants are a master and up to 32 slaves. The master controls the whole data flow, the slaves collect the data and pass them on. Physically the Interbus S is based on the interface standard RS 485 with a data transmission rate of 300 kbit/s. It requires a screened, drilled sx-wire line as transmission medium.

An addressing of the participants via the data frame is deleted as each participant can determine via special control signals in which position of the ring he is placed. According to the Interbus S-data protocol all participants are taken as one logic participant.

VEGACOM 557 is a slave on Interbus S with a defined module determination, enquired cyclically and updated via the sum frame of the master telegram. An Interbus S-module operates as master, which is used as component e.g. in a DCS. The master has three so called address windows. These windows are during the physical addressing (addressing corresponds to the place in the ring) coordinated to certain types of slave modules, with the logical addressing (address defined by the user) individually coordinated. With the physical addressing VEGACOM 557 is coordinated to window 2. The connection of physical and logical address configuration is documented via an address list which is stored as data component in the DCS or in an EEPROM-memory card.

Within the data traffic via the BUS, VEGACOM 557 is requested by the master to file a certain value in the input channel of the next module. The telegram consists of 6 Octetts, hence Octett no. 6 gives the number of the measured value to be read. The answer of VEGACOM 557 in the input channel consists also of 6 Octetts:

- Octett no. 1/2: Index / Status
- Octett no. 3/4: Measured value
- Octett no. 5/6: Failure information

The access to these data is made via loading/transfer commands in the DCS-program.

### 3.3 Modbus

VEGACOM 557 in Modbus-protocol version ensure the coupling of level and pressure measuring systems with DCS or processing systems via the Modbus-protocol.

With the Modbus centrally controlled master/slave systems with up to 247 participants can be realized. Basis are the interface standards RS 232, RS 422 and RS 485 as well as partly TTY. The max. line length is 1200 m.

The RTU-mode (= Remote Terminal Unit) or the ASCII-mode are used as transmission mode. Each participant has a fixed instrument address. VEGACOM as Modbus-participant is a slave. A DCS or a PLC operates as master.

Within the data traffic via the bus, VEGACOM is requested by the master, to emit DCS-values from DIS-BUS or LOGBUS in form of register data bytes to the bus. The enquiry telegram of the master includes:

- instrument address of VEGACOM to Modbus
- Function code  
04 = Read Input Registers  
08 = Diagnostic
- Address of the 1. Register in the Modicon-register memory
- Number of registers
- Check sum (failure control).

The answer of VEGACOM consists of the following data:

- Instrument address of VEGACOM to Modbus
- Function code
- Number of register data bytes
- Register data
- Check sum (failure control).

The register data are indication values of VEGAMET, DCS-values from VEGALOG as well as error and status information. The register data are written in the register memory of the DCS/PLC and processed.

### 3.4 Profibus DP

VEGACOM 557 in Profibus DP-version (= dezentrale peripherie) ensures the connection of level and pressure measuring systems to a Profibus data line. It has the function of a passive peripheral instrument (Slave).

Profibus determines the technical and functional features of a standard field-bus system by which separated digital field automation instruments in the lower (Sensor/Actor-stage) up to the mean efficiency range (cell stage) can be connected. Profibus distinguishes between Master and Slave-instruments.

**Master-instruments** determine the data traffic on the bus. A master is allowed to send messages without external request provided the master has the permission for bus access. In the Profibus-protocol masters are also called active participants.

**Slave-instruments** are easy peripheral instruments. Typical slave instruments are sensors, actuators, transmitters. They have no permission for bus access, i.e. they are only allowed to acknowledge received messages or to transfer messages to the master upon its request. Slaves are also called passive participants. They require only a small part of the bus protocol therefore very less expenditure required for implementation of the bus protocol.

The Profibus-version DP optimized to speed is especially suitable for communication between automation systems and the decentral peripheral instruments. Profibus DP is suitable as replacement of expensive parallel signal transmission with 24 Volt and the transmission of measured values in 0/4 ... 20 mA-technology.

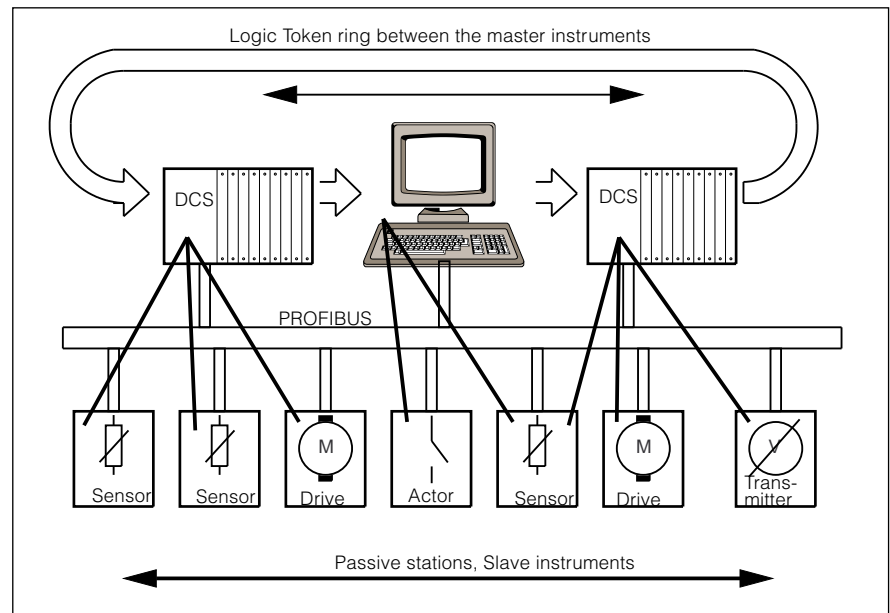

Fig. 3.1 Hybride bus access procedure with Profibus DP and FMS

Profibus DP is based on DIN 19 245, part 1 and application specific extensions, determined in the German standardization DIN 19 245 part 3 (published 1993). With the European fieldbus standardization, Profibus DP is integrated in the European fieldbus standard pr EN 50 170.

### Protocol architecture

Profibus is based on a number of accepted international and national standards. The protocol architecture is oriented on the OSI (Open System Interconnection) reference model, according to the international standard ISO 7498.

### Profibus layer 1 (Physical Layer)

The application range of a fieldbus system is generally determined by the selection of the transmission medium and the physical bus interface. Beside the requirements to the transmission reliability, the procurement and installation of the bus cable is of decisive importance. The Profibus-standard different kinds of transmission by keeping a unique bus protocol.

### Profibus layer 2 (Data Link Layer)

The second layer of the OSI-reference model realizes the functions of the bus access control, the data security as well as the treatment of the transmission protocols and the telegrams. Layer 2 is called Fieldbus Data Link (FDL) with Profibus.

The Profibus-bus access procedure includes therefore the Token-Passing-procedure for communication between complex bus participants (master) and supports the master-slave-procedure for communication of the complex bus participants with the peripheral instruments (slaves). This combined procedure is called hybride bus access procedure.

RS 485 is used as interface standard. The network topology is that of a linear bus with active end on both sides. As bus participant 126 master and slave instruments can be installed.

As master instruments e.g. Siemens communication processors IM 308 or CP 5431 can be used. The planning of such a bus system is made on the DCS-side (e.g. a Siemens S5), including the Profibus-Master. The planning software COM ET 200 is used on Windows. Typical planning elements are the definition of the type file, the configuration of the master system as well as the parameter adjustment of the slave.

The communication initiative is taken by the master, requiring via telegram the output of measured values from the slave. Each measured value consists of 3 data words (6 byte) including index and status information. The measured values are transmitted in 32 blocks with with 8 measured values each.

VEGACOM 557 is accompanied by a diskette with the measured data components DB 220 to DB 235 as well as the function components FB 180 to FB 183 and 190. The user includes these components into its user program.

## 3.5 Profibus FMS

VEGACOM 557 in the FMS-version (= Fieldbus Message System) enables the connection of level and pressure measuring systems to a Profibus-data line. VEGACOM 557 has the function of a passive peripheral instrument (Slave).

The bus access is realized acc. to the Master-Slave-procedure, enabling the master (e.g. a Simatic S5 with the communication component CP 5431) to collect data from the slave.

Profibus FMS has several elements in common with the Profibus DP. The short information to master/slave instruments, to the protocol architecture and to the Profibus layers 1 and 2 of section "3.4 Profibus DP" are also valid for this section "3.5 Profibus FMS". Profibus FMS however has an additional layer, layer 7.

### Profibus layer 7 (Application Layer)

Layer 7 of the ISO/OSI-reference model provides useful communication services to the user. These application services ensure the efficient, open data traffic between application processes. The Profibus application layer is specified in DIN 19 245 part 2 and consists of:

- Fieldbus Message Specification (FMS) and
- Lower Layer Interface (LLI).

**FMS** describes the communication objects, the application services and the resulting models from the view of the communication partner.

**LLI** is used for adaption of the application functions to the various features of Profibus layer 2.

### 3.6 Siemens 3964 and 3964 R-Prozedur

RS 485 is used as interface standard. The network topology is that of a linear bus with active end on both sides. As bus participant up to 126 master and slave instruments can be used.

As master instruments e.g. Siemens communication processors can be used CP5431. The planning of such a bus system is made on the DCS-side including the Profibus-Master, e.g. a Simatic S5. The planning software NCM (Network and Communication Management) based on the STEP5/S5-basic package is used. Typical planning elements are the preparation of an object index (OV), the connection attributes as well as the communication list (KLB). In addition the parameter adjustment for the S5-communication processor CP 5431 must be carried out.

The communication initiative is made by the master, which can e.g. via function component FB 210 input all 256 measured values in 16 blocks.

VEGACOM 557 is accompanied by a diskette with basic adjustment component DB 240, measured value components DB 220 to DB 235 as well as the function components FB 210 to FB 212. The user includes these components in its user program.

VEGACOM 557 in Siemens 3964 and 3964 R-version enables level and pressure measuring systems the connection to the Siemens communication processors CP 524 and CP 525.

The coupling is made as point-to-point connection via the interface standards RS 232, RS 422, RS 485 or TTY.

Within the data traffic VEGACOM is requested by the communication processor, to transmit indication values and switching conditions of the relays. The data are stored in the source data components 3 or 5 and can be collected via function components. The user has to make the parameter adjustment for the handling components FETCH (FB 246) and RECEIVE (FB 245). The Siemens programming package COM 525 is available for this purpose.

Each VEGAMET provides 3 indication values with 4 bytes (2 data words) each, which are stored in the DB sequentially, starting with DW 6. On VEGALOG also 4 bytes (2 data words) per indication value (function component) are provided. With 256 function components 2 data components (DB) are required. DB 3 and 4 must be supplied via handling components FB 245 and FB 246.

For filing of the relay information per VEGAMET and per LOGBUS-card 1 data word is occupied.

In addition to the indication values the measuring unit as well as the status/failure information is transmitted.

### 3.7 Technical data and dimensions

#### General data

#### Power supply

|                   |  |
|-------------------|--|
| Operating voltage | $U_{\text{enn}}$ = 24 V AC (20 ... 53 V), 50/60 Hz or<br>= 24 V DC (20 ... 72 V) |
| Power consumption | appr. 6 VA   |
| Fuse              | 1 A, slow-blow   |

#### Electrical connection

|   |  |
|---|--|
| Component                                       | multiple plug acc. to DIN 41 612, series F<br>48-pole (d, b, z) with coding holes        |
| Module in the carrier BGT 596<br>or BGT LOG 571 | suitable multipoint connector to DIN 41 612 with<br>connection via standard technologies |
| Housing type 505                                | via screw terminals max. 1 x 1,5 mm <sup>2</sup>   |

#### Indicating elements

|                    |   |
|--------------------|---|
| LED in front plate | green BA: communication signal (bus activity)<br>red (flashing): DISBUS-/LOGBUS-failure<br>red (permanently): Failure<br>green on: operating voltage on |
|--------------------|---|

#### Measuring data input DISBUS

|                   |                                    |
|-------------------|------------------------------------|
| Data transmission | DISBUS (digital data transmission) |
| Connection line   | 2-wire, unshielded (standard line) |
| Line length       | max. 1000 m                        |

#### Measuring data input LOGBUS

|                   |                                    |
|-------------------|------------------------------------|
| Data transmission | LOGBUS (digital data transmission) |
| Connection line   | connection via BUS-plug            |

#### PC-interface

|                                 |   |
|---------------------------------|---|
| Interface standard              | RS 232 C  |
| Line length                     | max. 15 m                                       |
| Transmission rate <sup>1)</sup> | 300, 600, 1200, 2400, 4800, 9600 and 19200 baud |
| Transmission format             | 8 data bits, 1 Stopbit, even parity             |
| Plug in the front plate         | D-SUB-plug connector, 9-pole, pins              |

#### Electrical protective measures

|  |                          |
|--|--------------------------|
| Protection:<br>not mounted<br>in carrier BGT 596<br>or BGT LOG 571 | IP 00                    |
| - front side completely equipped                                   | IP 40                    |
| - upper- and lower side<br>BGT 596                                 | IP 00                    |
| - wiring side<br>BGT LOG 571                                       | IP 20                    |
| - wiring side  | IP 00                    |
| in housing type 505  |                          |
| - front side   | IP 40                    |
| - other sides  | IP 30                    |
| Protection class   | II (in housing type 505) |
| Overvoltage category   | II                       |

#### Electrical separating measures

|  |   |
|--|---|
| Reliable separation acc. to VDE 0106, part 1 | between power supply, LOGBUS, DISBUS,<br>PC-connection and respective interface |
| - limit voltage                              | 250 V   |
| - test voltage                               | 3 kV  |

#### CE-approval, conformity judgement

VEGACOM 557 meets the protective regulations of EMVG (89/336/EWG) and NSR (73/23/EWG). The conformity has been judged acc. to the following standards:

|      |           |                     |
|------|-----------|---------------------|
| EMVG | Emission  | EN 50 081 - 1: 1993 |
|      | Immission | EN 50 082 - 2: 1995 |
| NSR  |           | EN 61 010 - 1: 1993 |

1) adjustable via DIL-switch on the component

**Mechanical data**

|                        |   |
|------------------------|---|
| Series                 | module unit for<br>- carrier BGT 596<br>- carrier BGT LOG 571<br>- housing type 505 |
| Dimensions not mounted | W = 25,4 mm (5 TE), H = 128,4 mm, D = 166 mm  |
| Weight                 | appr. 550 g   |

**Ambient conditions**

|                                   |                                       |
|-----------------------------------|---------------------------------------|
| Permissible ambient temperature   | -20°C ... +60°C                       |
| Storage and transport temperature | -20°C ... +85°C                       |
| Humidity                          | 93 %, T = 40°C acc. to DIN/IEC 68-2-3 |
| Shock load                        | 2 ... 100 Hz, 0,7 g                   |

**ASCII-interface**

**Interface data**

| Interfaces                      | RS 232  | RS 422 | RS 485 |
|---------------------------------|---|--------|--------|
| Max. line length                | 30 m  | 1200 m | 1200 m |
| Connection line                 | 3-wire  | 5-wire | 3-wire |
| Transmission rate <sup>1)</sup> | drilled in pairs, if necessary screened<br>300, 600, 1200, 2400, 4800, 9600, 19200 and 38400 baud |        |        |
| Transmission format             | 7 data bits or 8 data bits, 1 Stopbit   |        |        |
| Parity <sup>1)</sup>            | NONE, ODD, EVEN   |        |        |
| Figure format                   | acc. to DIN 66 003 (ASCII-Code)   |        |        |

**Interbus S-interface**

**Interface data**

|                     |  |
|---------------------|--|
| Interface standard  | Interbus S acc. to DIN 19 258 (standard sample)  |
| Instrument          | participant (module)   |
| Data width          | 8 Oktett (Byte) in the sum frame<br>- 6 Oktett cyclically<br>- 2 Oktett in the PCP-channel |
| Galvanic separation | 0,5 kV received against emitted interface  |

**Modbus-interface**

**Interface data**

| Interfaces                      | RS 232  | RS 422 | RS 485 |
|---------------------------------|---|--------|--------|
| Max. line length                | 15 m  | 1200 m | 1200 m |
| Connection line                 | 3-wire  | 5-wire | 3-wire |
| Kind of transmission            | drilled in pairs, if necessary screened<br>serially asynchronous, half duplex |        |        |
| Transmission rate <sup>1)</sup> | 300, 600, 1200, 2400, 4800, 9600, 19200 and 38400 baud                        |        |        |
| Galvanic separation             | up to 0,5 kV  |        |        |
| Modbus RTU-Mode <sup>2)</sup>   | 8 Bits binary, hexadecimal  |        |        |
| - Coding system                 | 1 Startbit, 8 data bits, 1 (0) Paritybit, 1 (2) Stopbit(s)                    |        |        |
| - Number of bits                | NONE, ODD, EVEN   |        |        |
| - Parity <sup>1)</sup>          | CRC <sup>3)</sup> - 16  |        |        |
| - Data security                 |   |        |        |
| Modbus ASCII-Mode <sup>4)</sup> | hexadecimal, ASCII-sign   |        |        |
| - Coding system                 | 1 Startbit, 7 data bits, 1 (0) Paritybit, 1 (2) Stopbit(s)                    |        |        |
| - Number of bits                | NONE, ODD, EVEN   |        |        |
| - Parity <sup>1)</sup>          | LRC <sup>5)</sup>   |        |        |
| - Data security                 |   |        |        |

1) adjustable via DIL-switch on the component  
 2) RTU = Remote Terminal Unit  
 3) CRC = Cyclic Redundancy Check  
 4) ASCII = American Standard Code for Information Interchange  
 5) LRC = Longitudinal Redundancy Check  
 6) BCC = Block Checking Character

**Siemens 3964- and 3964 R-interface****Interface data**

|                                 | RS 232  | RS 422 | RS 485 |
|---------------------------------|---|--------|--------|
| Interfaces                      | 15 m  | 1200 m | 1200 m |
| Max. line length                | 3-wire  | 4-wire | 2-wire |
| Connection line                 | drilled in pairs, with braiding screen and metal housing plug |        |        |
| Kind of transmission            | serially asynchronous, half duplex                            |        |        |
| Transmission rate <sup>3)</sup> | 110, 300, 600, 1200, 2400, 4800, 9600, 19200 baud             |        |        |
| Coding system                   | 8 Bits binary   |        |        |
| Number of bits                  | 1 Startbit, 8 data bits, 1 Paritybit, 1 Stopbit               |        |        |
| Data security                   | BCC <sup>3)</sup>   |        |        |

**Profibus FMS-interface****Interface data**

|                                  |   |
|----------------------------------|---|
| Standard conformity              | to DIN 19 245, part 1 and part 2<br>to pr EN 50 170<br>acc. to ISO 7498           |
| Interface standard               | RS 485  |
| Network topology                 | linear bus (active bus connection on both ends),<br>stub cables are possible      |
| Number of stations per segment   | 32 stations   |
| - without repeater <sup>1)</sup> | up to 127 stations  |
| - with repeater                  |   |
| Max. Bus length                  |   |
| - without repeater               | 100 m at 12 Mbits/s   |
| - Cable A                        | 200 m at 1500 kbits/s   |
|                                  | up to zu 1200 m at 93,75 kbits/s  |
| - Cable B                        | 200 m at 500 kbits/s  |
|                                  | up to zu 1200 m at 93,75 kbits/s  |
| - with repeater                  | up to in den 10 km-Bereich  |
| Connection line                  | 2-wire screened <sup>2)</sup> , drilled   |
| Kind of transmission             | half duplex, serially asynchronous,<br>absolute synchronization without deviation |
| Transmission rate <sup>3)</sup>  | 9,6; 19,2; 93,75 kbits/s up to 1200 m   |
|                                  | 187,5 kbits/s up to 600 m   |
|                                  | 500 kbits/s up to 200 m   |
| Coding system                    | NRZ-Code  |
| Number of bits                   | 11 Bits: 1 Startbit, 8 data bits, 1 Paritybit, 1 Stopbit                          |
| Parity                           | EVEN  |
| Data security                    | LRC   |

**Profibus DP-interface****Interface data**

|                                 |   |
|---------------------------------|---|
| Standard conformity             | to DIN 19 245, part 3   |
| Interface standard              | RS 485  |
| Network topology                | linear bus (active bus connection on both ends)                                   |
| Bus access                      | hybride bus access protocol acc. to<br>DIN 19 245, part 1                         |
| Max. number of bus participants | 126 Master and Slave-instruments  |
| Communication structure         | point-to-point or Multicast   |
| Communication procedure         | cyclical or acyclical   |
| Max. Bus length                 |   |
| - without repeater              | 100 m at 12 Mbits/s   |
|                                 | 200 m at 1500 kbits/s   |
| - with repeater                 | extendable up to 1200 m   |
| Connection line                 | 2-wire screened <sup>2)</sup> , drilled in pairs                                  |
| Kind of transmission            | half duplex, serially asynchronous,<br>absolute synchronization without deviation |
| Transmission rate <sup>3)</sup> |   |
| - Line A <sup>4)</sup>          | 9,6; 19,2; 93,75 kbits/s up to 1200 m   |
|                                 | 187,5 kbits/s up to 1000 m  |
|                                 | 500 kbits/s up to 400 m   |
| - Line B <sup>4)</sup>          | 9,6; 19,2; 93,75 kbits/s up to 1200 m   |
|                                 | 187,5 kbits/s up to 600 m   |
|                                 | 500 kbits/s up to 200 m   |
| Telegram formats                | acc. to DIN 19 245, part 1  |
| E-/A-data per DP-slave          | max. 246 Byte, typ. 32 byte   |
| Data security                   | Hamming distance HD = 4   |

1) Repeater = Line amplifier (at least 3 are possible, partly up to 10)

2) Screening can be deleted dependent on the ambient conditions (EMC)

3) adjustable via DIL-switch on the component

4) acc. to DIN 19 245, part 3

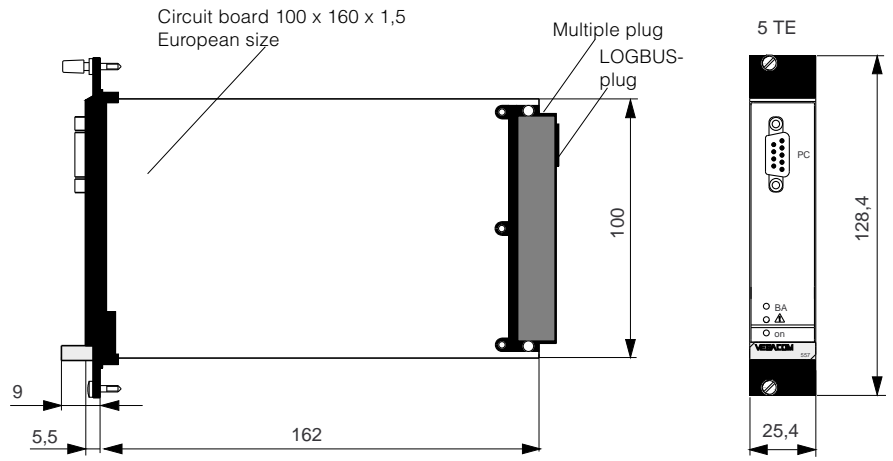

## 4 Mounting and installation

### 4.1 Mounting and connection instructions

VEGACOM 557 gateway can take over measured data and status information in two different ways:

- via DISBUS (from measuring systems with VEGAMET)
- via LOGBUS (from measuring systems with VEGALOG).

With DISBUS-configurations VEGACOM 557 can be either mounted into carrier BGT 596 or in housing type 505.

In conjunction with LOGBUS VEGACOM 557 is mounted into carrier BGT LOG 571. The plug position is individually selectable, the system is provided with an auto configuration.

A mechanical coding system avoids interchanging of different module cards in the carrier or housing.

The coding system consists of:

- three coded pins in the multipoint connector
- three holes in the multiple plug of VEGACOM 557.

The coded pins are attached to the module or housing. The multipoint connector is provided by the user with the coded pins acc. to the following table and figure:

|             | Instrument coding | Function coding |
|-------------|-------------------|-----------------|
| VEGACOM 557 | a 27              | c3/c11          |

Instrument coding

Function coding

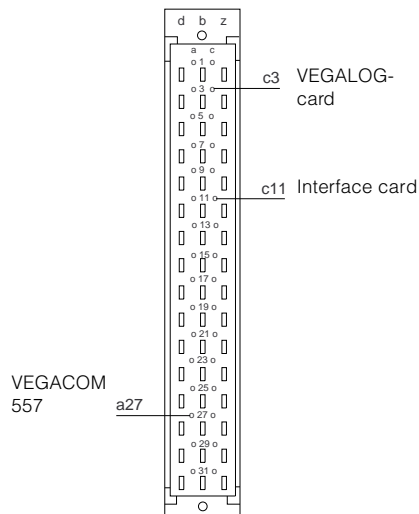

### 4.2 Mounting into carrier and housing

#### BGT 596 or BGT LOG 571

For installation you just have to provide a module in the desired position. A module consists of:

- a multipoint connector acc. to DIN 41 612, series F, 48-pole (d, b, z)
- two screws
- two coded pins
- two guide rails.

The multipoint connector is available as follows:

- Wire-Wrap, standard connection 1,0 mm x 1,0 mm
- Plug connection 2,8 mm x 0,8 mm
- Termi-Point standard connection 1,6 mm x 0,8 mm
- Soldering connection
- Screw terminals 0,5 mm<sup>2</sup>.

When mounting the module observe the operating instruction of the carrier.

#### Housing type 505

This housing is already provided with a multipoint connector. Check before installation whether the housing is provided with or without power supply.

The connection is made via screw terminals with max. 1,5 mm<sup>2</sup>.

## 5 Electrical connection

### 5.1 Connection instructions

For electrical connection generally observe the following instructions:

- the connection must be carried out acc. to the national installation standards (e.g. in Germany acc. to VDE-regulations).
- the voltage supply of VEGACOM 557 must be made with extra-low voltage, to keep protection class II. When using VEGASTAB 593-60 or 593 a reliable separation of the mains circuits acc. to DIN/VDE 0106, part 101 is fulfilled.
- use a strain relief for the connected cables and lines, available as VEGA-accessory. This is also the earth terminal for screened lines.

### 5.2 Connection plans

#### D-SUB-plug (front plate)

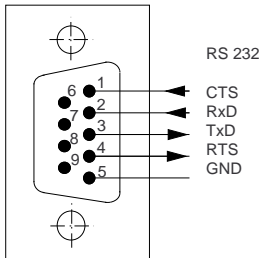

| Pin | Description         | I/O |
|-----|---------------------|-----|
| 1   | CTS clear to send   | I   |
| 2   | RxD receive data    | I   |
| 3   | TxD transmit data   | O   |
| 4   | RTS request to send | O   |
| 5   | GND ground          | -   |

**Note:**

VEGACOM 557 operates without Hardware-Handshake, i.e. RTS and CTS are not wired.

#### ASCII-Code

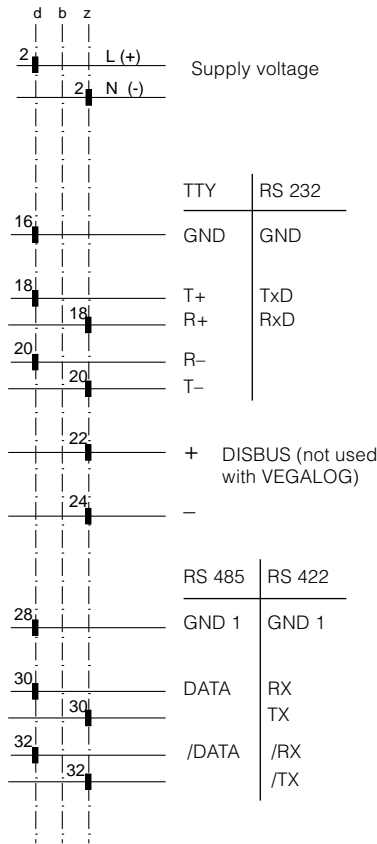

#### Interbus S

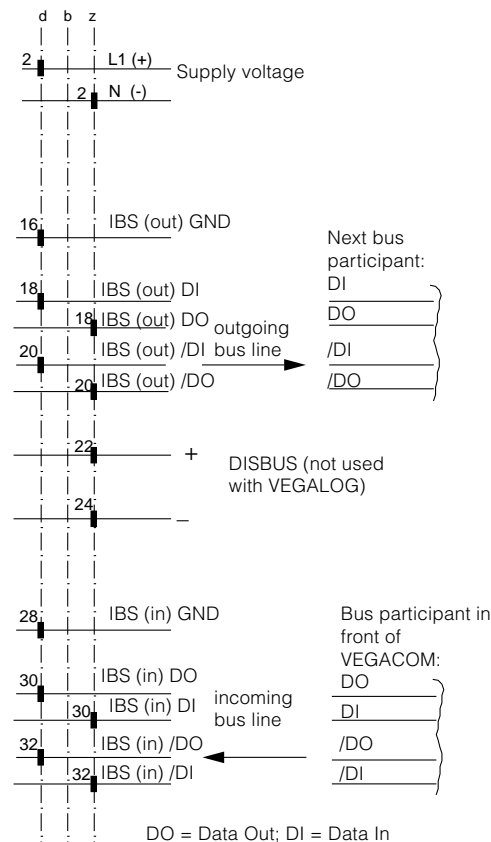

### Modbus

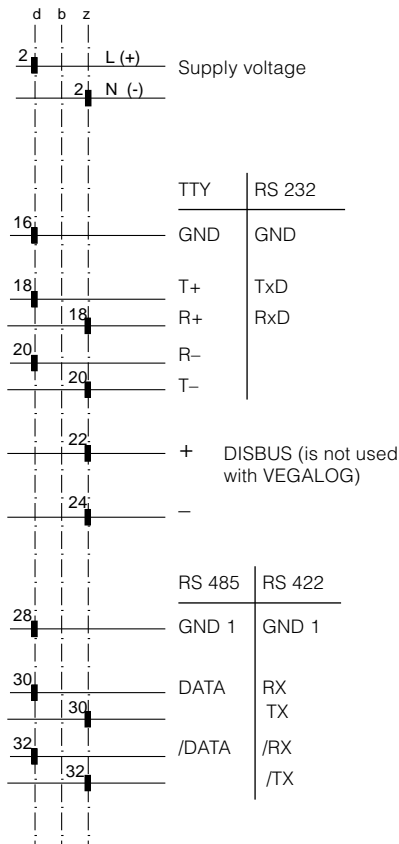

### Profibus FMS and DP

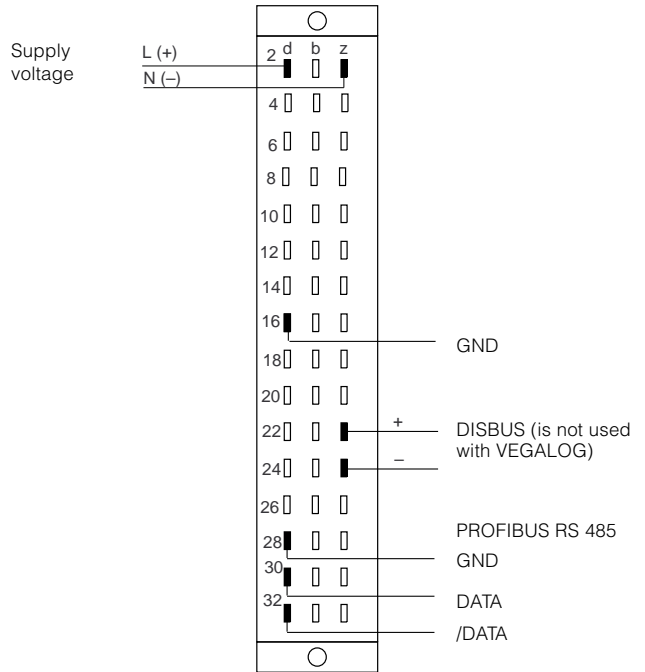

### Siemens 3964 and 3964 R

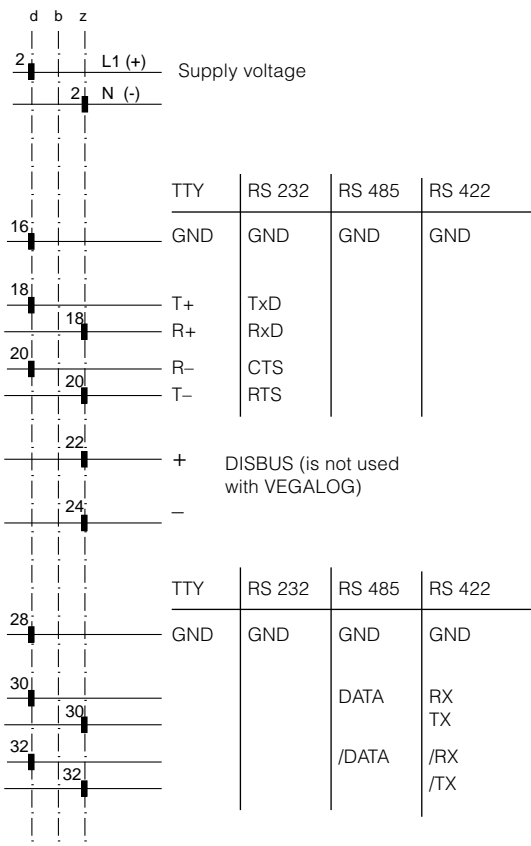

## 6 Order code

### VEGACOM 557

- Communication protocol**  
A Siemens S5 (3964 R-procedure)  
B Modbus (RTU and ASCII)  
I Interbus S  
P Profibus (FMS and DP)  
N ASCII

COM 557.X  Order number for Software



VEGA Grieshaber KG  
Am Hohenstein 113  
D-77761 Schiltach  
Phone (0 78 36) 50 - 0  
Fax (0 78 36) 50 - 201  
Fax (0 78 36) 50 - 203

**Australia**

VEGA Australia Pty. Ltd.  
(A.C.N. 003 346 905)  
11/17, Clearview Place  
P. O. Box 11 41  
Brookvale  
NSW 2100  
Phone (02) 99 39 17 11  
Fax (02) 99 39 63 26

**België, Luxemburg**

VEGA N. V.  
J. Tieboutstraat 67  
1731 Zellik  
Phone (02) 4 66 05 05  
Fax (02) 4 66 88 91

**China**

Tianjin-VEGA Co. Ltd.  
95, Zhi Cheng Road  
Hebei District  
Tianjin City  
Phone (0 22) 6 27 32 96  
Fax (0 22) 6 27 32 97

Tianjin VEGA Co. Ltd.  
Shanghai Office  
Bailemen Hotel, Room 508  
Mr. Ling Quan Sheng  
1728 Nan Jing Xi Road  
Shanghai 200040  
Phone (0 21) 2 48 86 86  
Fax (0 21) 2 48 68 69

**France**

VEGA Technique S.A.  
BP 18  
Nordhouse  
67151 Erstein-Cédex  
Phone (88 98) 1818  
Telex 89 05 26  
Fax (88 98) 18 33

**Great Britain**

VEGA Controls Ltd.  
Kendal House  
Victoria Way  
Burgess Hill  
West Sussex, RH 15 9NF  
Phone (0 14 44) 87 00 55  
Fax (0 14 44) 87 00 80

**Italia**

VEGA ITALIA S.r.l.  
Via G. Watt 37  
20 143 Milano  
Phone (02) 89 12 40 08  
Fax (02) 89 12 40 14

**Nederland**

VEGA Industriële Automatisering  
Postbus 210  
3800 AE Amersfoort  
Phone (0 33) 4 50 25 02  
Fax (0 33) 4 56 14 14

**Österreich**

VEGA-Österreich  
Moosbergweg 57  
4810 Gmunden  
Phone (0 76 12) 54 25 0  
Fax (0 76 12) 5 06 49

**Schweiz**

VEGA-MESSTECHNIK AG  
Barzloostrasse 2  
8330 Pfäffikon ZH  
Phone (01) 9 50 57 00  
Fax (01) 9 50 57 13

**Singapore**

VEGA Grieshaber Singapore  
Block 134 #02-309 C  
Jurong East Street 13  
Singapore 2260  
Phone 5 64 05 31  
Fax 5 67 52 13

**USA, Canada**

Ohmart Corp.  
4141 Allendorf Drive  
Cincinnati, Ohio 45209  
Phone (05 13) 272 - 0131  
Fax (05 13) 272 - 0133

