

Product Information

VEGALOG 571 processing system

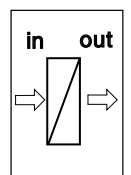
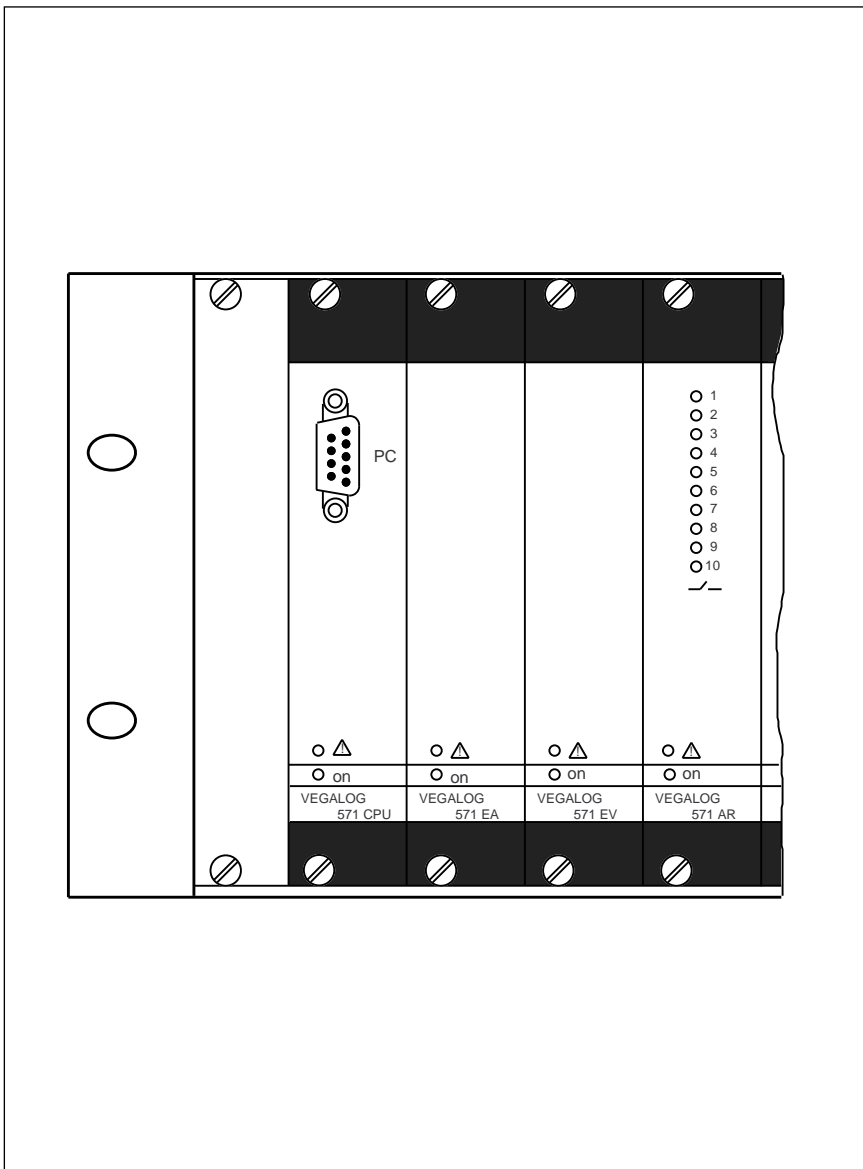

Contents

1	Product description	3
2	Function and application	
2.1	Function, adjustment	4
2.2	Configuration and parameter adjustment	4
2.3	Visualization, communication	5
2.4	Measuring system, application examples	5
3	Types and versions	
3.1	CPU-cards	10
3.2	Input cards	10
3.3	Output cards	11
3.4	Technical data and dimensions	12
4	Mounting	
4.1	Carrier BGT LOG 571	17
4.2	Mounting into the carrier	17
4.3	Coordination survey	18
5	Electrical connection	
5.1	General connection instructions	19
5.2	Wiring instructions for the EV-card	19
5.3	Installation examples for the EV-card	19
5.4	Connection plans	20
5.5	Additional instructions for Ex-applications	22
6	Order code	
6.1	Central unit with interface RS 232	23
6.2	Carrier BGT LOG 571	23
6.3	Module VEGALOG 571	23

1 Product description

VEGALOG 571 is a powerful, modular processing system suitable for a wide range of applications such as e.g.:

- level measurement
- density measurement
- tank gauging
- level detection
- process pressure measurement
- differential pressure measurement, etc.

According to the individual requirements VEGALOG 571 can be equipped with several module cards in 19"-format. CPU cards and peripheral cards are available which can be plugged into the carrier BGT LOG 571. This carrier is in 19"-standard formation and ensures the communication between the module cards via the integral LOGBUS.

The CPU-card takes over the complete communication among the individual cards. In addition the CPU-card is responsible for all calculating tasks such as e.g. scaling, linearization, differential generation with a difference measurement etc.

A D-SUB-plug with a RS 232-interface is located in the front plate of the CPU-card. A PC for configuration and parameter adjustment of the system and for visualization of the process data can be directly connected to this interface.

The peripheral cards are the interface to the process. They power the connected sensors and process their measured data for evaluation in the CPU. The following sensors can be connected to the peripheral cards:

- capacitive electrodes
- hydrostatic pressure transmitters
- ultrasonic sensors
- radar sensors
- process and differential pressure transmitters
- analog external sensors.

Outputs of the peripheral cards or CPU as:

- current signal 0/4 ... 20 mA
- voltage signal 0/2 ... 10 V
- DISBUS-signal
- relay or transistor contact

The following peripheral cards are available:

Input cards

- EA-card for connection of max. 10 sensors with analog signal transmission or max. 10 switching contacts
- EV-card for connection of max. 10 sensors with digital signal transmission (VBUS)

Output cards

- AA-card with 10 analog current outputs
- AD-card for connection of max. 2 x 15 VEGADIS 174 indicators
- AR-card with 10 relay outputs (spdt)
- AT-card with 10 transistor outputs

Communication card

- VEGACOM 557 for connection to standard field bus systems e.g. via the data formats Siemens 3964 R, Modbus, ASCII, Interbus S, Profibus FMS and DP.

Power supply card

- VEGASTAB 593 for supply of the cards with 24 V DC in two versions 60 W and 120 W
- VEGASTAB 594 with 33 V DC, 60 W

User advantages

- Individual selectable and extensible according to requirements.
- Universal system for connection of individual sensors.
- Auto configuration, i.e. the modules are individually selectable and an address is not required
- Central processing system for up to 255 measuring points.
- A sensor can be used for several measuring points.
- Up to 32 modules in two carriers available.
- Comfortable adjustment via PC with VVO operating software.

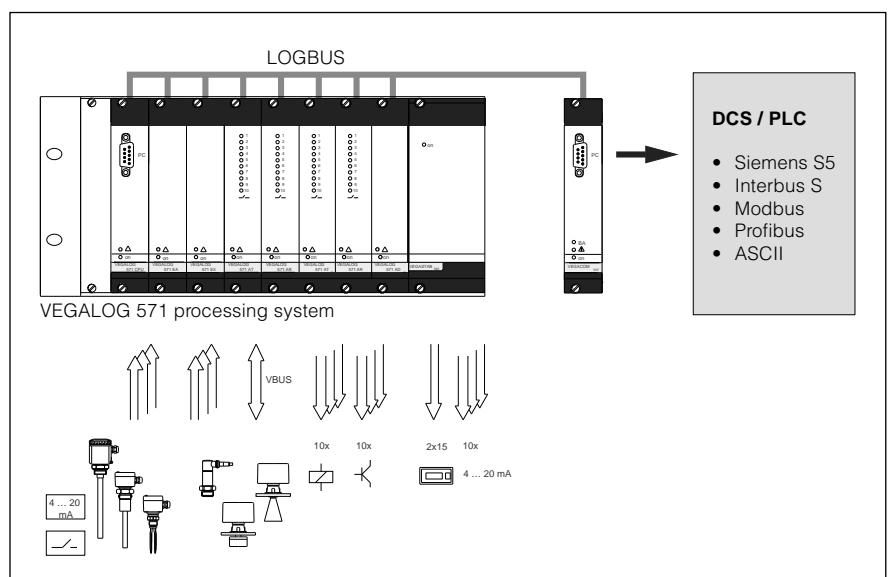

Fig. 1.1 VEGALOG 571 processing system with a wide range of input and output possibilities

2 Function and application

2.1 Function, adjustment

Function

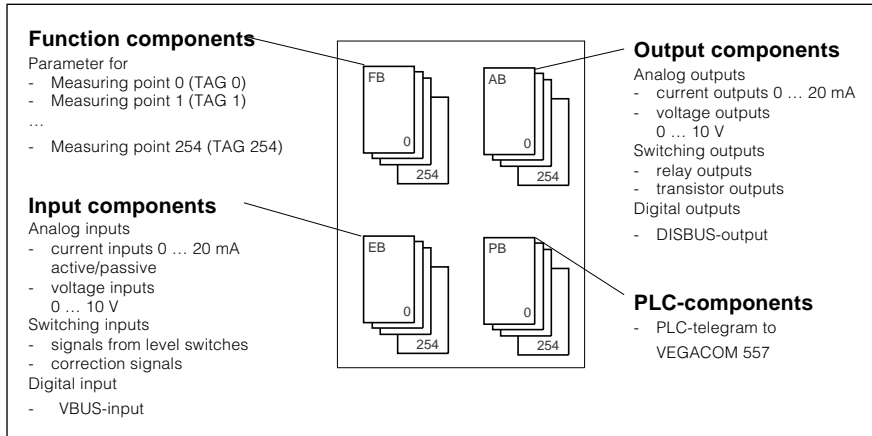

Fig. 2.1 The software of VEGALOG 571 consists of two different component types

The processing of the measured data is made in the CPU via a special software, consisting of function components (FB), input components (EB), output components (AB) as well as PLC-components (PB). In total max. 255 components are available which are automatically provided by the system when a measuring point is configured.

Adjustment

The adjustment of VEGALOG 571 is made via PC with VEGA Visual Operating (VVO) operating software. The PC is connected via a RS 232-cable to the PC-interface of the CPU-card. If your VEGALOG is also provided with an integral VEGACOM 557, the PC can be also connected to the VEGACOM 557 PC-interface.

The set-up with VVO is always the same: first configuration, then parameter adjustment.

2.2 Configuration and parameter adjustment

The configuration of a measuring system means a coordination of the individual components in an instruments, e.g. the linking of an input with an output or the providing of addresses for bus communication. Normally the configuration is made once and sets the measuring system into operating condition.

The parameter adjustment means the modification of individual values (e.g. modification of the min./max.-adjustment, the integration time etc.). The already configured measuring system is adapted optimally to the application.

Configuration

At first the configuration is made in two steps:

- configuration of the measuring system (instrument oriented)
- configuration of the individual measuring points (application oriented)



Fig. 2.2 Main menu of the configuration



Fig. 2.3 Example of a configuration

The configuration of the measuring system includes e.g. the selection of the module cards and modules, the determination of the failure reaction, the coordination of the VBUS-sensors etc. All these measures are instrument oriented and concern the whole measuring system.

The configuration of the individual measuring points coordinates to each measuring point inputs and outputs, e.g. sensor inputs, current and switching outputs etc. Hence this configuration is application oriented: a choice is made out of existing applications (function components), the individual measuring point is the result of this procedure.

The application oriented input of measuring points is supported by graphic means such as e.g. vessel drawings and pictographs which change according to the selected frame conditions and options.

Due to the graphic support also more complex parameter adjustments can be easily carried out such as e.g. the input of a linearization curve by means of index markers.

Parameter adjustment

Following to the configuration the parameter adjustment is carried out, i.e. the optimum adaption to the application. For any previously configured measuring point, measuring point oriented values are modified, e.g. min./max.-adjustment, integration time but also values of the outputs coordinated (configured) to this measuring point, e.g. switch on and off points of the relays etc.



Fig. 2.4 Main menu of the parameter adjustment



Fig. 2.5 Parameter adjustment of instrument data

User advantages

- Easy set-up.
- Clear operating surface by menu structure, window technology and graphic support.
- Operating surface to VDI/VDE-regulations 2187.
- Backup on PC, hence the set-up data are always available

2.3 Visualization, communication

Visualization

With the Visual VEGA (VV) visualization software the measured values of VEGA-processing systems can be demonstrated in graphic and tabular form. Measured value and status information are transmitted via the RS 232-interface of VEGACOM 557 or the VEGALOG CPU-card to the PC. These measuring points can be composed to groups. Hence direct comparisons of several measuring points are possible. In addition levels and fault signals can be indicated.

The measured values can be stored on PC. The cycle and the storage period can be adjusted according to the requirement. The history data can be either shown in tabular or graphic form. The data conversion in a file in ASCII-format ensures the data transfer with other programs.

Several processing systems can be connected to a PC via an interface converter. Visual VEGA can be connected to a network and can be used on several computers at the same time.

Communication

By means of the VEGACOM 557 interface converter measured data and status information of the CPU and peripheral cards can be composed and transferred digitally. For this reason VEGACOM is plugged like a VEGALOG-card into the carrier and accesses to the LOGBUS.

VEGACOM takes over the conversion of protocols from VEGA-specific, for level applications optimized bus systems, to a standardized data format.

The collected data are converted to the following standard data formats:

- Siemens S5
- Modbus
- ASCII
- Interbus S
- Profibus FMS or DP.

This means easy integration of the level data into existing control systems. By using the VEGACOM 557 interface converter networked systems can be already realized which already meet with future requirements. For adaption to a new protocol proven sensors and signal conditioning instruments must not be modified, but just the interface converter must be exchanged.

User advantages

- VEGACOM 557 as interface for visualization and adjustment.
- Due to interface technology with VEGACOM 557 open to new standards.
- Reliable network: Sensors and signal conditioning instruments remain even when the fieldbus protocol is changed.
- Digital communication from sensor via signal conditioning instrument and display up to the DCS/PLC.

2.4 Measuring system, application examples

2.4.1 Measuring system

A complete measuring system consists of the following components:

- sensor
- VEGALOG-input card
- VEGALOG-CPU

Necessary accessories:

- carrier BGT LOG 571
- VEGASTAB 593-60, VEGASTAB 593 or VEGASTAB 594 power supply

Recommended accessory:

- overvoltage arresters for sensor and VEGALOG-input card

2.4.2 Application examples with individual sensors

Level measurement

Standard

- Sensor: Capacitive electrodes
- Hydrostatic pressure transmitters
- Ultrasonic sensors
- Radar sensors
- Process pressure transmitters
- Differential pressure transmitters

Kind: Standard

Option: Correction in the point

- Real value correction
- Zero-point correction
- Density correction

Parameter: Level

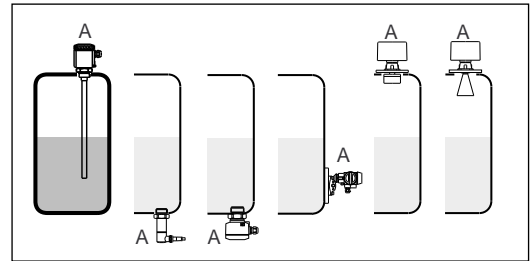

Fig. 2.6 Level measurement

Tank gauging

Standard

- Sensor: Hydrostatic pressure transmitters
- Ultrasonic sensors
- Radar sensors

Kind: Standard

Option: none

Parameter: Gauge

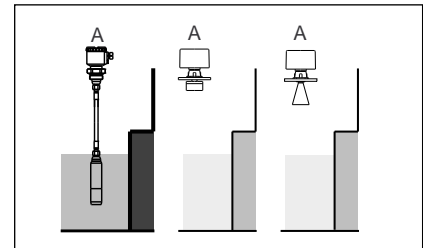

Fig. 2.7 Tank gauging

Process pressure measurement

Standard

- Sensor: Process pressure transmitters
- Differential pressure transmitters

Kind: Standard

Option: Zero-point correction

Parameter: Process pressure

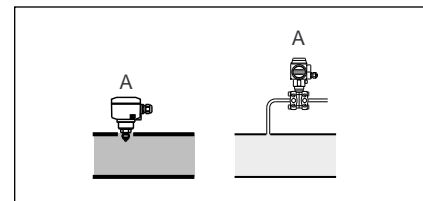

Fig. 2.8 Process pressure measurement as standard pressure measurement

Difference

- Sensor: Differential pressure transmitters

Kind: Difference

Option: none

Parameter: Pressure difference

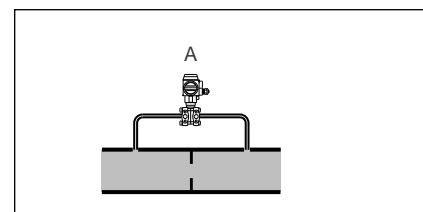

Fig. 2.9 Process pressure measurement as differential pressure measurement

Flow measurement

Standard

Sensor: Hydrostatic pressure transmitters
 Ultrasonic sensors
 Radar sensors
 Kind: Standard
 Option: none
 Parameter: Flow

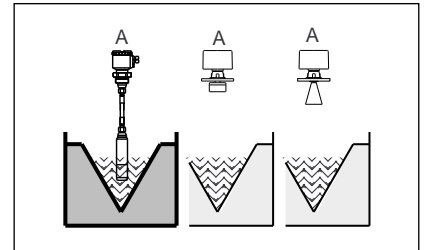

Fig. 2.10 Flow measurement

Distance measurement

Standard

Sensor: Ultrasonic sensors
 Radar sensors
 Kind: Standard
 Option: none
 Parameter: Distance

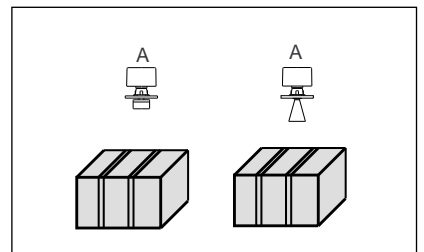

Fig. 2.11 Distance measurement

Level detection

Standard

Sensor: Capacitive electrodes
 Vibrating level switch
 Kind: Standard
 Option: none
 Parameter: Level

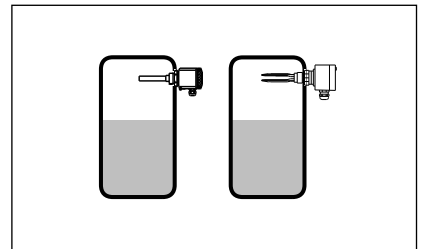

Fig. 2.12 Level detection

Connection of a switching contact

Standard

Sensor: External switching contact
 Kind: Standard
 Option: none
 Parameter: Switching condition

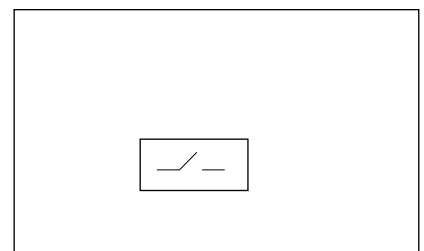

Fig. 2.13 Connection of an external switching contact

Connection of a 4 ... 20 mA-instrument

Standard

Sensor: 4 ... 20 mA-instrument (active)
 Kind: Standard
 Option: none
 Parameter: Current

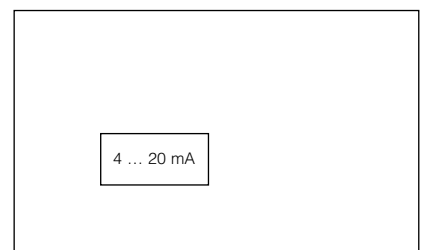

Fig. 2.14 Connection of a 4 ... 20 mA-instrument

2.4.3 Application examples with sensor pairs

Level measurement

Pressurized vessel

- Sensor: Hydrostatic pressure transmitters
Process pressure transmitters
- Kind: Pressurized
- Option: Zero-point correction
Real value correction
Density correction
- Parameter: Level
Overpressure
Total pressure

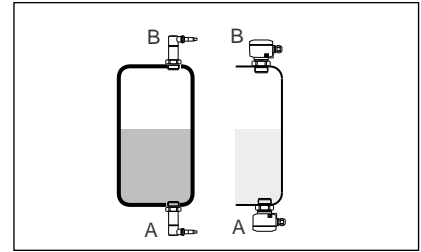

Fig. 2.15 Level measurement in pressurized vessel

Product with variable density (density compensation)

- Sensor: Hydrostatic pressure transmitters
Process pressure transmitters
- Kind: Variable density
- Option: Zero-point correction
Real value correction
Density correction
- Parameter: Level
Density
Uncorrected level

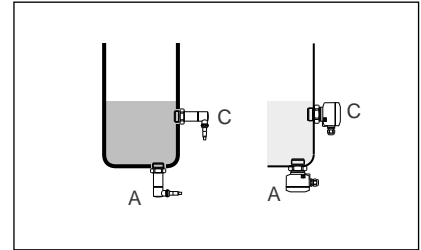

Fig. 2.16 Level measurement, product with variable density (density compensation)

Level difference

- Sensor: Hydrostatic pressure transmitters
Ultrasonic sensors
Radar sensors
- Kind: Difference
- Option: Real value correction (only with hydrostatic pressure transmitters)
- Parameter: Level 1
Level 2
Level difference

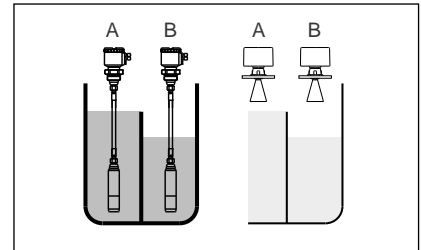

Fig. 2.17 Level measurement, level difference

Tank gauging

Gauge difference

Sensor:	Hydrostatic pressure transmitters Ultrasonic sensors Radar sensors
Kind:	Difference
Option:	Real value correction (only with hydrostatic pressure transmitters)
Parameter:	Gauge upstream water Gauge downstream water Gauge difference

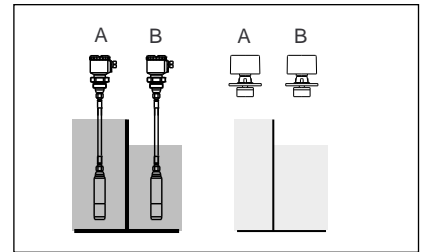

Fig. 2.18 Tank gauging as gauge difference measurement

Process pressure measurement

Difference

Sensor:	Process pressure transmitters
Kind:	Difference
Option:	Real value correction
Parameter:	Process pressure 1 Process pressure 2 Pressure difference

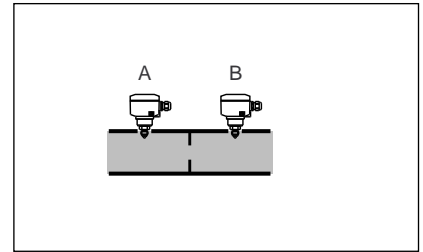

Fig. 2.19 Process pressure measurement as differential pressure measurement

Density measurement

Standard

Sensor:	Hydrostatic pressure transmitters Process pressure transmitters
Kind:	Standard
Option:	Zero-point correction
Parameter:	Density Level Uncorrected level

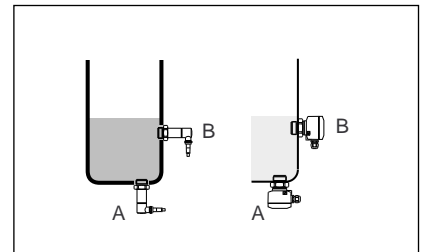

Fig. 2.20 Density measurement

3 Types and versions

The modular system of VEGALOG 571 consists of different, special module card types:

- CPU-cards
- input cards
- output cards
- communication cards for connection to standard bus systems
- power supply card for feed of cards

3.1 CPU-cards

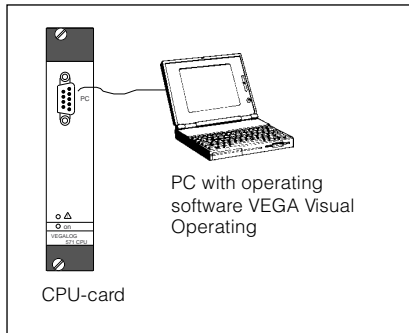

Fig. 3.1 CPU-card

This card is the heart of VEGALOG. It has the following functions:

- communication between the individual cards
- calculatory tasks such as scaling, linearization, differential determination etc.
- coupling to PC via RS 232-interface

In addition the CPU is used for level detection or monitoring of switch on and off times. Via the integral real time clock time functions, e.g. for flow measurement can be realized.

Acc. to the number of measuring points, CPU-cards in different efficiency stages up to 15, 30, 60 or 255 measuring points are available.

The CPU inputs in 300 ms-cycle measured values from the peripheral cards. These are compared with the programmed data, standardized and processed. The programmed data (configuration data, adjustment parameters etc.) are in the EEPROM where they remain even in case of voltage failure. In the memory of the CPU a process picture is produced which is provided via the LOGBUS to the peripheral cards.

For data protection the programmed data can be provided any time via the RS 232-interface on the PC and stored there on fixed disc or disc.

3.2 Input cards

EA-card

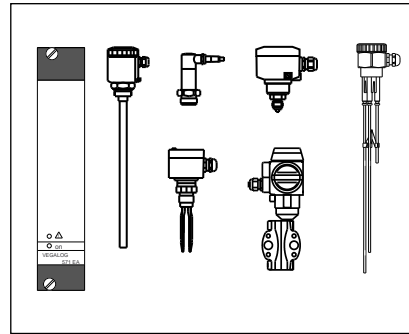

Fig. 3.2 EA-card

Up to 10 sensors can be connected via active* current inputs 0 ... 20 mA to the EA-card (input card analog):

- capacitive electrodes
- hydrostatic pressure transmitters
- vibrating level switches
- conductive electrodes
- process pressure and differential pressure transmitters

The inputs can be also parameter adjusted as passive* and are used for connection of:

- switching contacts
- external current sources 0 ... 20 mA.

Within an EA-card also a mixed parameter adjustment of active/passive* inputs is permissible.

EV-card

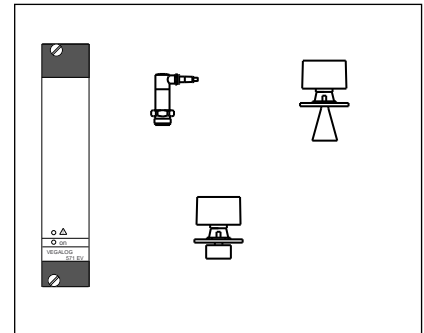

Fig. 1.3 EV-card

The EV-card (EV = input VBUS) feeds up to 15 VBUS-sensors and processes their data:

- hydrostatic pressure transmitters
- ultrasonic sensors
- radar sensors

The digital communication between the sensors and the EV-card ensures that several even different VBUS-sensors can be connected via a common two-wire line to the EV-card. This provides a kind of transmission with high reliability perfectly adapted to the conditions of level measurement technology. It ensures additionally to the general transmission of measured values also the parameter adjustment of the sensors via the signal conditioning instrument from the control room (local parameter adjustments are carried out via the PC with VVO).

* Input active = Sensor passive
Input passive = Sensor active

3.3 Output cards

AA-card

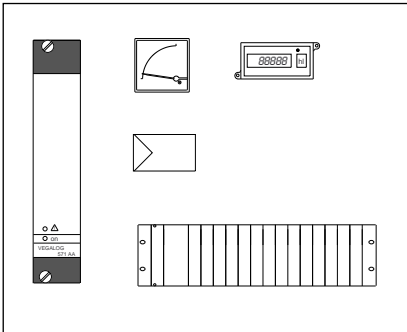

Fig. 3.4 AA-card

The AA-card (AA = output analog) provides the processing results via up to 10 analog currents in the 0 ... 20 mA range. The scaling as well as the definition as raising or falling characteristics is made via PC with VVO.

Indicating instruments, recorders, controllers or DCS-systems are connected to these outputs.

AD-card

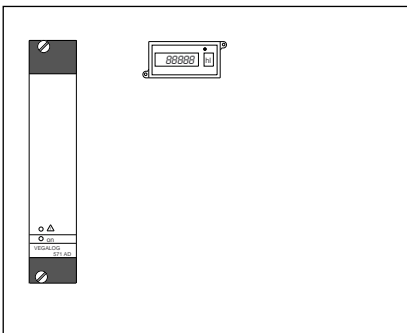

Fig. 3.5 AD-card

The AD-card (AD = output DISBUS) brings max. 15 measured values to one DISBUS-line. Up to 30 VEGADIS 174 indicating instruments can be connected to this line.

AR-card

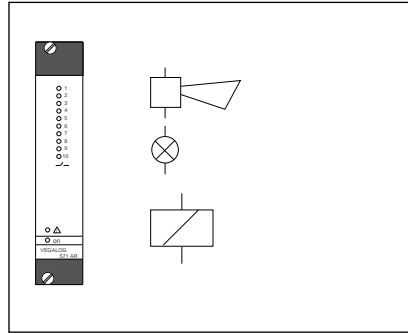

Fig. 1.6 AR-card

The AR-card (AR = output relay) provides 10 relay outputs with floating spdt. Connection of:

- acoustic or optic signallers
- magnetic valves
- contactors
- etc.

The AR-card is suitable to trigger level, individual or sum fault signals. The switching condition of each relay is indicated via a two-colour LED in the front. This LED lights acc. to the parameter adjustment of the relay as level contact yellow or as failure relay red. Each relay can be individually coordinated to one or several measuring points. The definition of the relay function, of the switch points as well as the LED-colour is made via PC with VVO.

AT-card

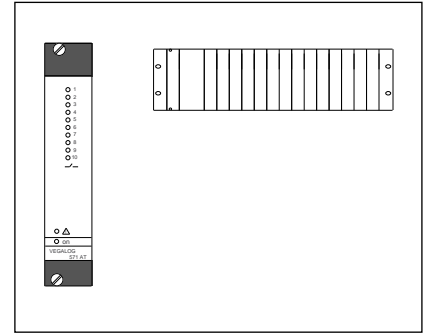

Fig. 1.7 AT-card

The AT-card (AT = output transistor) provides 10 floating outputs via NPN-transistors. Binary input cards of DCS-systems can be connected.

The application possibilities and the signalling of switching condition correspond to the AR-card.

3.4 Technical data and dimensions

General data

Power supply

Operating voltage	U_{nenn} = 24 V AC (18 ... 28 V), 50/60 Hz or = 24 V DC (16 ... 36 V)
Power consumption	
- CPU-card	max. 6 W
- EA-card	max. 11 W
- EV-card	max. 10 W
- AA-card	max. 9 W
- AD-card	max. 10 W
- AR-card	max. 6 W
- AT-card	max. 6 W
Fuse	1 A slow-blow

Electrical connection

Module card	multiple plug acc. to DIN 41 612, series F, 48-pole (d, b, z) with coding holes
Module in the carrier BGT LOG 571	suitable multipoint connector acc. to DIN 41 612 with connection via usual connection technologies

Electrical protective measures

Protection not mounted in carrier BGT LOG 571	IP 00
- front side completely equipped	IP 40
- upper and lower side	IP 20
- wiring side	IP 00
Protection class	I (in carrier BGT LOG 571)
Overvoltage category	II

CE-conformity

The module cards of VEGALOG 571 meet the protective regulations of EMVG (89/336/EWG) and NSR (73/23/EWG). The conformity has been judged acc. to the following standards:

EMVG	Emission	EN 50 081
	Immission	EN 50 082
NSR		EN 61 010

Mechanical data

Series	module cards for carrier BGT LOG 571
Dimensions unassembled	W = 25,4 mm (5 TE), H = 128,4 mm (3 HE), D = 166 mm
Weight per card	appr. 400 g

Ambient conditions

Permissible ambient temperature	-20°C ... +60°C
Storage and transport temperature	-20°C ... +80°C

CPU-card

Interfaces

To LOGBUS RS 232 via PC	via LOGBUS-plug on the module card via 9-pole D-SUB-socket (pins) in the front plate of the module card
----------------------------	---

Electrical separating measures

Galvanic separation acc. to VDE 0106, part 1	between power supply, LOGBUS-connection and RS 232-interface
- limit voltage	250 V
- isolation resistance	2,3 kV

Indicating elements

LED in front plate	green (on): operating voltage on red: fault signal
--------------------	---

EA-card**Measuring data inputs**

Number	10 inputs
Kind	analog two-wire input, active or passive also mixed
Range	0 ... 20 mA
Sensors	capacitive electrodes hydrostatic pressure transmitters vibrating level switches conductive electrodes process pressure and differential pressure transmitters
Further connection possibilities	external current sources 0 ... 20 mA, switching contact
Sensor supply voltage	24 V DC
Current limitation	per sensor circuit 26,5 mA, permanently shortcircuit proof
Max. input voltage	24 V DC
Switching threshold	adjustable via operating software VVO in the range 4 ... 20 mA
Min. hysteresis	80 µA (fixed)
Linearity error	0,1 % of range (for input active and passive)
Average raising error	0,5 % of range (nur only for input passive)
Temperature error	0,025 %/10 k of range
Connection line	2-wire (standard line)
Resistance per conductor	max. 35 Ω

Interfaces

To LOGBUS	via LOGBUS-plug on the module card
-----------	------------------------------------

Electrical separating measures

Galvanic separation acc. to VDE 0106, part 1	between power supply, LOGBUS-connection and measuring data inputs
- limit voltage	250 V
Common reference potential	between the individual measuring data inputs (GND)

Indicating elements

LED in front plate	green (on): mains voltage on red: fault signal
--------------------	---

EV-card**Measuring data inputs**

Number	15 inputs
Data transmission	digital (VBUS)
Sensors	hydrostatic pressure transmitters ultrasonic sensors radar sensors
Sensor supply voltage	24 V DC, short-circuit proof
Integral current limitation	
- internal sensor supply	0,25 A
- external sensor supply	1 A (for 5 sensors each)
Connection line	2-wire (standard line or screend) ¹⁾
Line length	max. 1000 m
Resistance per conductor	max. 200 Ω for hydrostatic transmitters ²⁾ max. 20 Ω for ultrasonic and radar sensors ²⁾

Interfaces

To LOGBUS	via LOGBUS-plug on the module card
-----------	------------------------------------

Electrical separating measures

Galvanic separation acc. to VDE 0106, part 1	between power supply, LOGBUS-connection and measuring data inputs
- limit voltage	250 V
Common potential	between VBUS-measuring data inputs

Indicating elements

LED in front plate	green (on): operating voltage on red: fault signal
--------------------	---

¹⁾ see section 3 Electrical connection

²⁾ the values are valid for one connected sensor. Observe reduction acc. to 3.4

AA-card

Current outputs

Number	10 outputs
Function	analog output of processing results
Range	0/4 ... 20 mA (current limitation or fault signal 22 mA)
Load	max. 750 Ω
Resolution	0,05 % of range (10 μA)
Linearity error	0,025 % of range
Temperature error	0,025 %/10 k of range

Interfaces

To LOGBUS	via LOGBUS-plug on the module card
-----------	------------------------------------

Electrical separating measures

Galvanic separation acc. to VDE 0106, part 1	between power supply, LOGBUS-connection and current outputs
- limit voltage	250 V
Common potential	between current outputs (GND)

Indicating elements

LED in front plate	green (on): mains voltage on red: fault signal
--------------------	---

AD-card

DISBUS-output

Number	1 output
Function	digital transmission of processing results und system information to VEGADIS 174 or VEGACOM 557
Number of instruments to be connected	max. 2 x 15 VEGADIS 174 max. 1 VEGACOM 557
Connection line	2-wire (standard line)
Line length	max. 1000 m

Interfaces

To LOGBUS	via LOGBUS-plug on the module card
-----------	------------------------------------

Electrical separating measures

Galvanic separation acc. to VDE 0106, part 1	between power supply, LOGBUS-connection and DISBUS-output
- limit voltage	250 V

Indicating elements

LED in front plate	green (on): operating voltage on red: fault signal
--------------------	---

AR-card**Relay outputs**

Number	10 outputs
Hysteresis	parameter adjustable
Contact	each 1 floating spdt AgNi and hard gold plated
Turn-on voltage	min. 10 mV DC max. 250 V AC, 60 V DC
Switching current	min. 10 μ A DC max. 2 A AC, 1 A DC
Breaking capacity	max. 125 VA, 54 W

Interfaces

To LOGBUS	via LOGBUS-plug on the module card
-----------	------------------------------------

Electrical separating measures

Reliable separation acc. to VDE 0106, part 1	from the relays to the power supply and LOGBUS-connection
- limit voltage	250 V
- isolation resistance	2,3 kV
Galvanic separation	between relays
- limit voltage	250 V
- isolation resistance	1,5 kV

Indicating elements

LED in front plate	green (on): operating voltage on yellow/red: switching condition as level / fail safe relay for each relay red: fault signal
--------------------	---

AT-card**Transistor outputs**

Number	10 outputs
Turn-on voltage	max. 28 V DC
Switching current ¹⁾ I _B	max. 10 mA DC
Breaking capacity	max. 0,3 W DC
Voltage loss U _{CE}	≤ 0,8 V at I _B = 10 mA

Interfaces

To LOGBUS	via LOGBUS-plug on the module cards
-----------	-------------------------------------

Electrical separating measures

Galvanic separation acc. to VDE 0106, part 1	between power supply, LOGBUS-connection and transistor outputs
- limit voltage	250 V
Potential separation	between transistor outputs
- limit voltage	50 V
- isolation resistance	0,5 kV

Indicating elements

LED in front plate	green (on): operating voltage on gelb/rot: switching condition as level / fail safe transistor for each output red: fault signal
--------------------	---

¹⁾ not shortcircuit proof, external current limitation recommended

Dimensions

(in mm)

The dimensions are shown on the example of the CPU-card, they are also valid for the other module cards of VEGALOG.

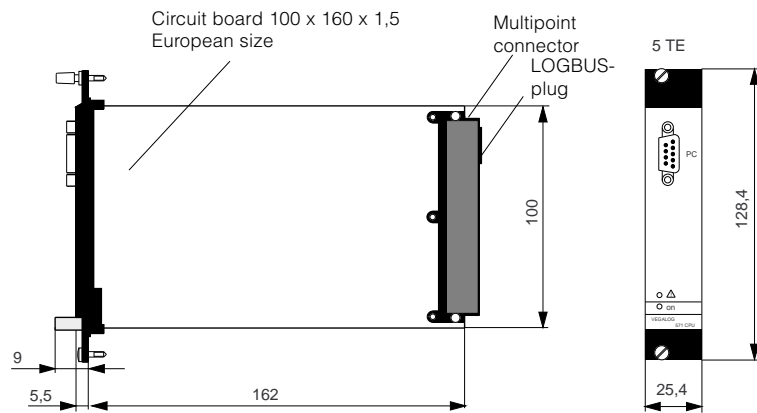

4 Mounting

4.1 Carrier BGT LOG 571

The module cards of VEGALOG 571 must only be installed in the 19"-carrier BGT LOG 571 as only this carrier is provided with a special bus board for data transmission between CPU and the individual peripheral cards of VEGALOG.

In fully equipped condition VEGALOG 571 consists of two carriers which are connected via a pluggable bus line (see "3 Electrical connection"). Therefore a mounting distance for air circulation must be provided between the two carriers.

4.2 Mounting into the carrier

The carrier BGT LOG 571 is completely assembled when being delivered. For installation of the individual cards modules must be provided in the requested positions. A module consists of:

- a multipoint connector acc. to DIN 41 612, series F, 48-pole (d, b, z)
- two screws
- two coded keys
- two guide rails.

The multipoint connector is available as follows:

- Wire-Wrap Standard connection
1,0 mm x 1,0 mm
- plug connection
2,8 mm x 0,8 mm
- Termi-Point Standard connection
1,6 mm x 0,8 mm
- soldering connection
- screw terminals 0,5 mm²

For installation of the module please observe the operating instruction of VEGALOG 571.

Dimensions

single line configuration

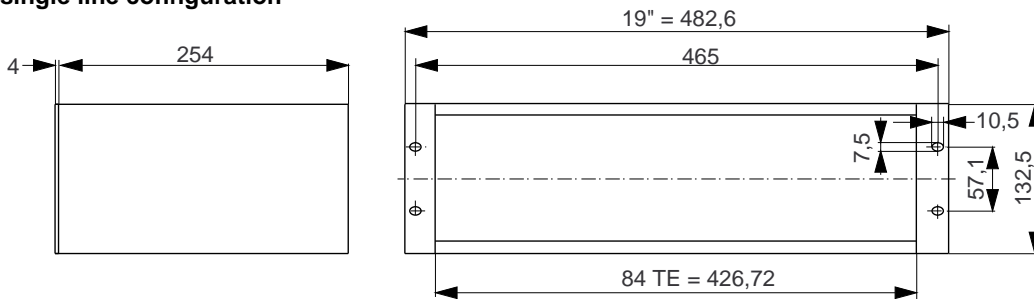

double row configuration

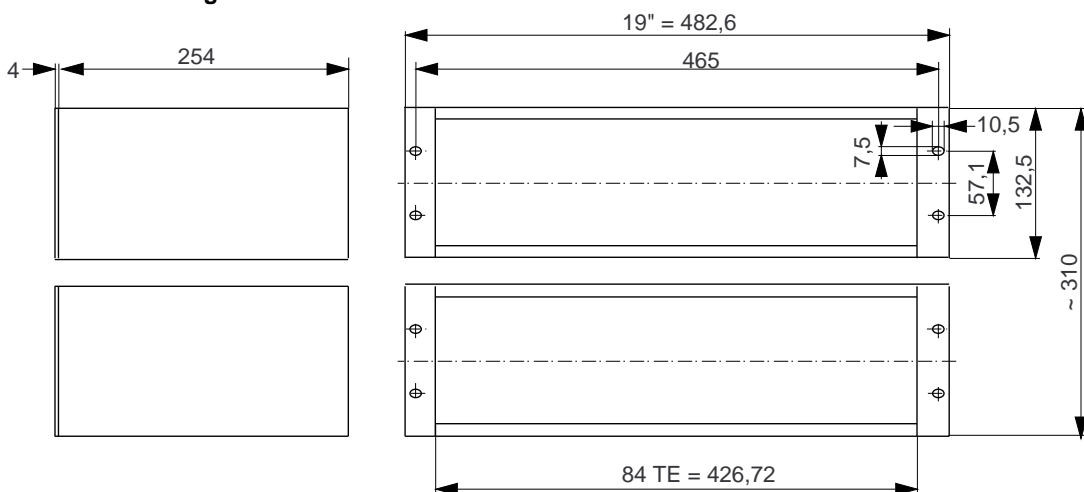

4.3 Coordination survey

The below schedule is used to give a survey on the coordinated modules and the used connection technology. Please determine the total power consumption of the module cards and ensure that the power requirements are catered for by the power supply.

	Number TE	TE-no. / Module																Figure St	Power W	ΣW		
		1 -	5 1	10 2	15 3	20 4	25 5	30 6	35 7	40 8	45 9	50 10	55 11	60 12	65 13	70 14	75 15				80 16	
CPU 15	5																				≤ 6	
CPU 30	5																				≤ 6	
CPU 60	5																				≤ 6	
CPU 255	5																				≤ 6	
Inputs																						
EA-card	5																				≤ 11	
EV-card	5																				≤ 10	
Sensors	5																					
Outputs																						
EA-card	5																				≤ 9	
AR-card	5																				≤ 6	
AT-card	5																				≤ 6	
AD-card	5																				≤ 10	

Σ_{Power} =

Power supply:																			
VEGASTAB 593																			
VEGASTAB 593-60																			
VEGASTAB 594																			

Conn.technology:																			
Wire-Wrap																			
Termi-Point																			
Plug connection																			
Soldering connec.																			
Screw terminals																			

Blind cover	4																		
Blind cover	5																		
Blind cover	10																		

5 Electrical connection

5.1 General connection instructions

For electrical connection generally observe the following instructions:

- The connection must be made acc. to the national standards (e.g. in Germany acc. to VDE-regulations).
- The wiring between input cards and sensors can be made via standard two-wire cable.
- If strong electromagnetic interferences have to be expected, we recommend to use screened cable. The screening must be earthed at one sensor side.
- The line resistors stated in the technical data must not be exceeded.
- The respective cross-section areas of conductor must be kept when several ultrasonic or radar sensors must be supplied via the EV-card.
- If overvoltages have to be expected, we recommend a sensor electronics with integral overvoltage arrester or the installation of VEGA-overvoltage arresters.
- The voltage supply of the VEGALOG-cards must be made with extra-low voltage, to keep protection class II. When using VEGASTAB 593 a reliable separation of mains circuits acc. to DIN/VDE 0106, part 101 is fulfilled.
- Secure the connected cable or lines by a strain relief which can be ordered as accessories from VEGA. The strain relief is furthermore used as earth terminal for screened lines.

5.2 Wiring instructions for the EV-card

The digital data transmission between VBUS-sensors and the EV-card enables the connection of several sensors via a common two-wire line. The following limit values are valid:

Pressure transmitters

Max. 15 to one two-wire line per EV-card.

Ultrasonic/Radar sensors

Max. 15 per EV-card, divided into three groups with 5 pcs. each on one two-wire line.

With ultrasonic/radar sensors division is necessary to the higher power consumption. Therefore the EV-card must be additionally supplied with a DC-voltage, e.g. 24 V. This voltage can be provided via the available or a separate power supply unit. Ensure that the power supply unit power is sufficient. If several EV-cards are supplied out of a common power supply unit with additional voltage, the connected sensors are galvanically combined. Each branch with max. 5 sensors is shortcircuit proof. The integral current limitation starts at 1,0 A.

Select the cross-section area of conductor such that the voltage loss on the respective two-wire line is as low as possible. The required cross-section depends on the power consumption of the sensors as well as on the used line length. Please observe the operating instruction VEGALOG 571.

5.3 Installation examples for the EV-card

Example 1:

A common bus line for five sensors each is led from the control room up to the last sensor of the group.

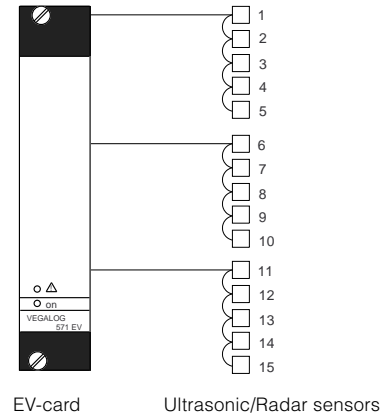

EV-card

Ultrasonic/Radar sensors

Example 2:

A common bus line for five sensors each is led from the control room up to the system and from there continues start-shaped to the sensors.

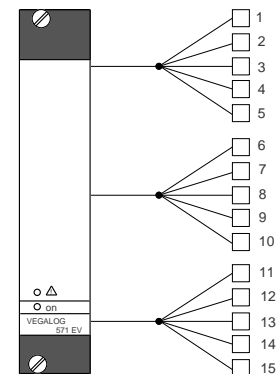

EV-card

Ultrasonic/Radar sensors

Example 3: (Pressure transmitter)

A common bus line for all 15 sensors is led from the control room up to the last sensor.

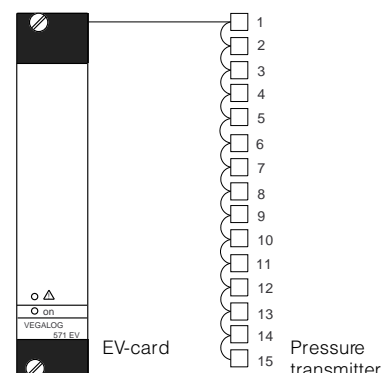

EV-card

Pressure transmitter

5.4 Connection plans

CPU-card

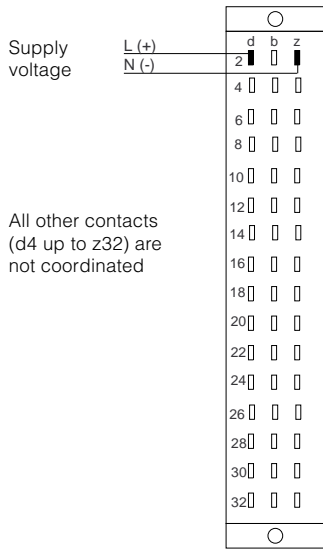

EV-card

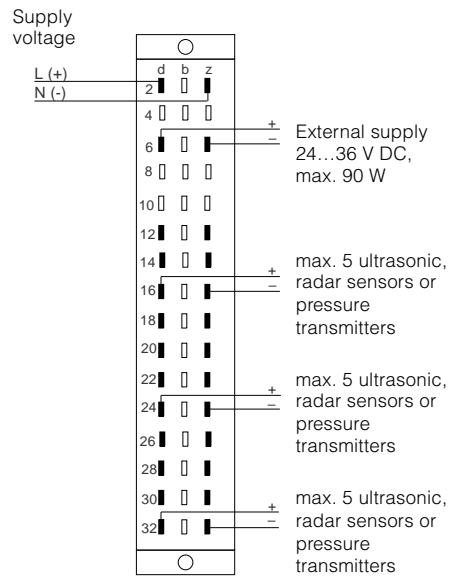

Note:

- The connections d12, d14 and d16 as well as d20, d22 and d24 as well as d28, d30 and d32 are each on one (+) potential
- The connections z12 ... z32 are on a common (-) potential
- With external supply the (+) potential is on the (+) potential of the external supply

EA-card

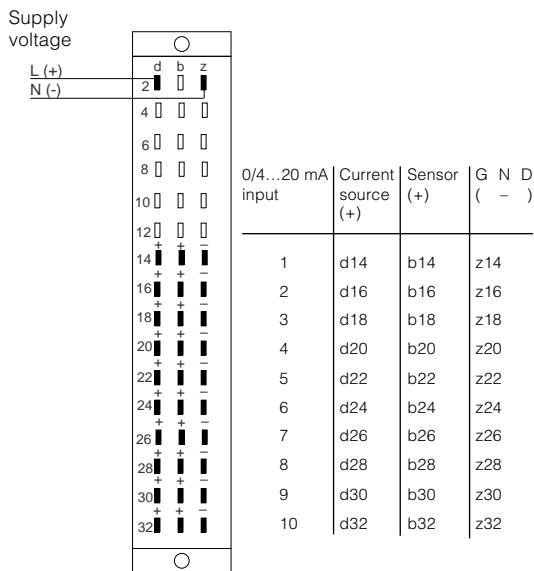

Note:

- All inputs 1 ... 10 are on a common GND (-) potential
- Instead of the current source, a voltage source can be connected, therefore a series resistor must be connected to the circuit (e.g. 500 Ω 1/4 W at 0 ... 10 V)

AA-card

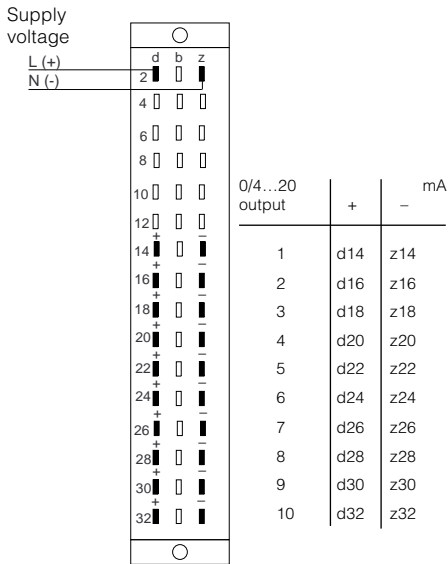

AR-card

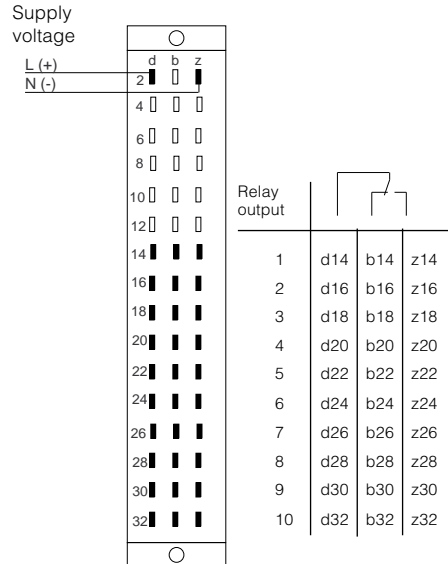

Note:

The connections z14 ... z32 are on a common GND (-) potential.

AD-card

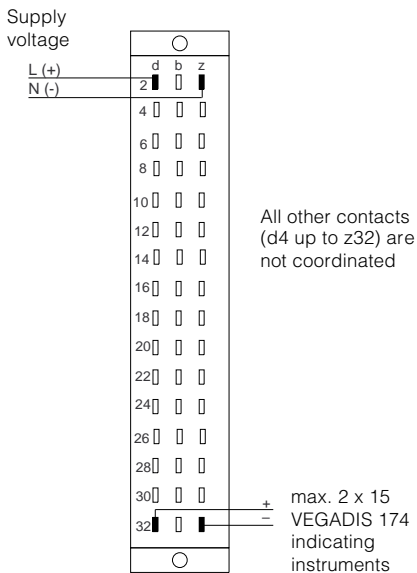

AT-card

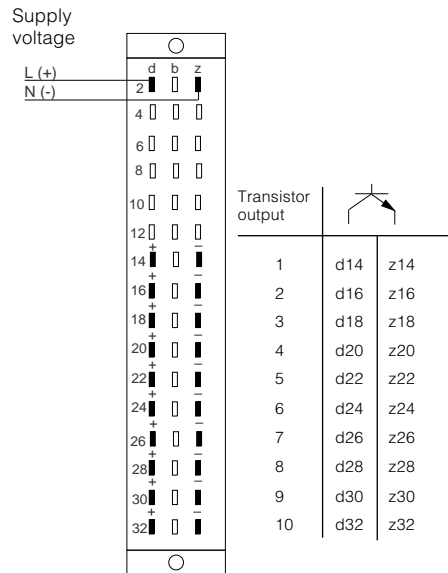

5.5 Additional instructions for Ex-applications

Applications in the area acc. to

- CENELEC Ex-regulations
 - ElexV (Germany) Zone 0
- require the use of approved sensors.

For these applications the respective legal documents (test reports, test certificates and conformity certificates) must be observed. These are supplied with the respective instrument.

The voltage supply of these sensors must only be made via an intrinsically safe circuit. Therefore the sensors are connected via respective separating facilities to the respective VEGALOG-input card:

- to the EA-card via a safety barrier type 145
- to the EV-card via a safety barrier type 146 or VEGATRENN 546 or via an Ex-separator VEGATRENN 547

The legal documents of these instruments must also be observed.

Installation instructions

Observe the following instructions for installation:

- VEGALOG 571 as well as the used separating facility must only be erected outside the Ex-area
- between connection parts of intrinsically safe and non-intrinsically safe circuits a separation wall must be inserted, so that there is a min. distance of 50 mm
- max. five safety barriers type 146 or VEGATRENN 546 can be connected to an EV-card
- only one sensor must be connected to each separator or safety barrier
- for VEGATRENN 546 a 32-pole Ex-module with 10 TE-width must be provided in the carrier
- for VEGATRENN 546 the following distances must be kept:
 - ≥ 10 mm to the left carrier wall (is ensured by blind cover 4 TE = 20,32 mm)
 - ≥ 6 mm to the left positioned not-Ex-component (is ensured by blind cover 2 TE = 10,16 mm)

Furthermore the respectively valid installation and operating regulations must be observed. The DIN/VDE-regulations prescribe, e.g. that the connection lines between separating facility and sensors must be permanently marked on their entire length. If the cover is coloured, the colour must be light-blue.

Connection instructions

The not-intrinsically safe input of the safety barrier type 145 is connected via a standard two-wire line to the EA-card.

The not-intrinsically safe input of the safety barrier type 146 or VEGATRENN 546 is connected via a standard two-wire line to the EV-card.

If electromagnetic interferences have to be expected, screened cable should be used. The screen must only be earthed at one end on the switching cabinet. The wiring of the intrinsically safe outputs of the safety barrier with the sensors (in hazardous areas) must be carried out acc. to the valid installation regulations. Furthermore the special conditions and information in the conformity certificates must be observed.

Connection examples

Safety barrier type 145

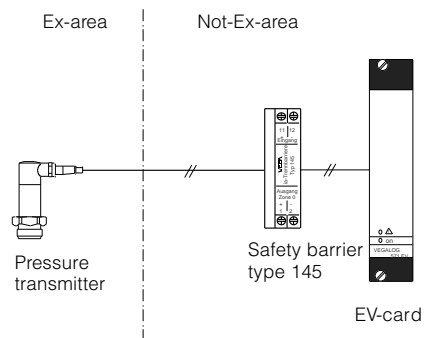

6 Order code

6.1 Central unit with interface RS 232

CPU (15) - card for max. 15 measuring points	LOG571CPU.B
CPU (30) - card for max. 30 measuring points	LOG571CPU.C
CPU (60) - card for max. 60 measuring points	LOG571CPU.D
CPU (255) -card for max. 255 measuring points	LOG571CPU.E

Input cards

EA-card	Input card for connection of max. 10 sensors with analog signal transmission (current, active or passive)	LOG571EA.
EV-card	Input card for connection of max. 15 sensors with digital signal transmission (VBUS)	LOG571EV.

Output cards

AA-card	Output card with 10 analog current outputs	LOG571AA.
AR-card	Output card with 10 relay outputs (spdt)	LOG571AR.
AT-card	Output card with 10 transistor outputs	LOG571AT.
AD-card	Output card for connection of max. 2 x 15 VEGADIS 174 indicating instruments	LOG571AD.

6.2 Carrier BGT LOG 571

19"-carrier for mounting in 19"-racks and housings	LOG571BT.M
--	------------

6.3 Module VEGALOG 571

For mounting in carrier BGT LOG 571

Connection

- A. Wire-Wrap, standard connection 1,0 mm x 1,0 mm
- B. Plug connection 2,8 mm x 0,8 mm
- C. Termi-Point standard connection 1,6 mm x 0,8 mm
- D. Soldering connection
- E. Screw terminals 0,5 mm²

STECKPLATZ-48 Order number for module VEGALOG 571

VEGA Grieshaber KG
Am Hohenstein 113
D-77761 Schiltach
Phone (0 78 36) 50 - 0
Fax (0 78 36) 50 - 201
Fax (0 78 36) 50 - 203

Australia

VEGA Australia Pty. Ltd.
(A.C.N. 003 346 905)
11/17, Clearview Place
P. O. Box 11 41
Brookvale
NSW 2100
Tel. (02) 99 39 17 11
Fax (02) 99 39 63 26

België, Luxemburg

VEGA N. V.
J. Tieboutstraat 67
1731 Zellik
Tel. (02) 4 66 05 05
Fax (02) 4 66 88 91

China

Tianjin-VEGA Co. Ltd.
95, Zhi Cheng Road
Hebei District
Tianjin City
Tel. (0 22) 6 27 32 96
Fax (0 22) 6 27 32 97

Tianjin VEGA Co. Ltd.
Shanghai Office
Bailemen Hotel, Room 508
Mr. Ling Quan Sheng
1728 Nan Jing Xi Road
Shanghai 200040
Tel. (0 21) 2 48 86 86
Fax (0 21) 2 48 68 69

France

VEGA Technique S.A.
BP 18
Nordhouse
67151 Erstein-Cédex
Tel. (88 98) 1818
Telex 89 05 26
Fax (88 98) 18 33

Great Britain

VEGA Controls Ltd.
Kendal House
Victoria Way
Burgess Hill
West Sussex, RH 15 9NF
Tel. (0 14 44) 87 00 55
Fax (0 14 44) 87 00 80

Italia

VEGA ITALIA S.r.l.
Via G. Watt 37
20 143 Milano
Tel. (02) 89 12 40 08
Fax (02) 89 12 40 14

Nederland

VEGA Industriële Automatisering
Postbus 210
3800 AE Amersfoort
Tel. (0 33) 4 50 25 02
Fax (0 33) 4 56 14 14

Österreich

VEGA-Österreich
Moosbergweg 57
4810 Gmunden
Tel. (0 76 12) 54 25 0
Fax (0 76 12) 5 06 49

Schweiz

VEGA-MESSTECHNIK AG
Barzloostrasse 2
8330 Pfäffikon ZH
Tel. (01) 9 50 57 00
Fax (01) 9 50 57 13

Singapore

VEGA Grieshaber Singapore
Block 134 #02-309 C
Jurong East Street 13
Singapore 2260
Tel. 5 64 05 31
Fax 5 67 52 13

USA, Canada

Ohmart Corp.
4141 Allendorf Drive
Cincinnati, Ohio 45209
Tel. (05 13) 272 - 0131
Fax (05 13) 272 - 0133

