

Operating Instructions

Electronics module

VEGAMIP series 60 - emitting unit

VEGAMIP series 60 - receiving unit



Document ID:
37349

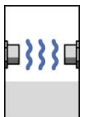

Radar

Contents

1	About this document	
1.1	Function	3
1.2	Target group	3
1.3	Symbolism used	3
2	For your safety	
2.1	Authorised personnel	4
2.2	Appropriate use	4
2.3	Environmental instructions	4
3	Product description	
3.1	Configuration	5
3.2	Principle of operation	5
3.3	Packaging, transport and storage	5
4	Mounting	
4.1	Mounting instructions	7
4.2	Mounting preparations	7
4.3	Mounting steps	7
5	Setup	
5.1	Setup	10
6	Maintain	
6.1	How to proceed in case of repair	11
7	Dismounting	
7.1	Dismounting steps	12
7.2	Disposal	12
8	Supplement	
8.1	Technical data	13

Safety instructions for Ex areas



Please note the Ex-specific safety information for installation and operation in Ex areas. These safety instructions are part of the operating instructions manual and come with the Ex-approved instruments.

1 About this document

1.1 Function

This operating instructions manual provides all the information you need for mounting, connection and setup as well as important instructions for maintenance and fault rectification. Please read this information before putting the instrument into operation and keep this manual accessible in the immediate vicinity of the device.

1.2 Target group

This operating instructions manual is directed to trained qualified personnel. The contents of this manual should be made available to these personnel and put into practice by them.

1.3 Symbolism used



Information, tip, note

This symbol indicates helpful additional information.



Caution: If this warning is ignored, faults or malfunctions can result.

Warning: If this warning is ignored, injury to persons and/or serious damage to the instrument can result.

Danger: If this warning is ignored, serious injury to persons and/or destruction of the instrument can result.



Ex applications

This symbol indicates special instructions for Ex applications.



List

The dot set in front indicates a list with no implied sequence.



Action

This arrow indicates a single action.



Sequence

Numbers set in front indicate successive steps in a procedure.

2 For your safety

2.1 Authorised personnel

All operations described in this operating instructions manual must be carried out only by trained specialist personnel authorised by the plant operator.

During work on and with the device the required personal protective equipment must always be worn.

2.2 Appropriate use

Oscillator, emitting electronics, housing or process components are replacement components for existing sensors.

2.3 Environmental instructions

Protection of the environment is one of our most important duties. That is why we have introduced an environment management system with the goal of continuously improving company environmental protection. The environment management system is certified according to DIN EN ISO 14001.

Please help us fulfil this obligation by observing the environmental instructions in this manual:

- Chapter "*Packaging, transport and storage*"
- Chapter "*Disposal*"

3 Product description

3.1 Configuration

Scope of delivery

The scope of delivery encompasses:

- Electronics module for emitting unit VEGAMIP series 60 (MP60EE.T**) or electronics module for receiving unit VEGAMIP series 60 (MP60EE.R**)
- Documentation
 - this operating instructions manual

3.2 Principle of operation

Application area

The electronics module MP60 is suitable as a replacement for the electronics of microwave barrier VEGAMIP series 60.

3.3 Packaging, transport and storage

Packaging

Your instrument was protected by packaging during transport. Its capacity to handle normal loads during transport is assured by a test according to DIN EN 24180.

The packaging of standard instruments consists of environment-friendly, recyclable cardboard. For special versions, PE foam or PE foil is also used. Dispose of the packaging material via specialised recycling companies.

Transport

Transport must be carried out under consideration of the notes on the transport packaging. Nonobservance of these instructions can cause damage to the device.

Transport inspection

The delivery must be checked for completeness and possible transit damage immediately at receipt. Ascertained transit damage or concealed defects must be appropriately dealt with.

Storage

Up to the time of installation, the packages must be left closed and stored according to the orientation and storage markings on the outside.

Unless otherwise indicated, the packages must be stored only under the following conditions:

- Not in the open
- Dry and dust free
- Not exposed to corrosive media
- Protected against solar radiation
- Avoiding mechanical shock and vibration

Storage and transport temperature

- Storage and transport temperature see chapter "*Supplement - Technical data - Ambient conditions*"

- Relative humidity 20 ... 85 %

4 Mounting

4.1 Mounting instructions

If the electronics module is defective, it can be replaced by the user.



In Ex applications only one instrument and one electronics module with respective Ex approval may be used.

4.2 Mounting preparations

Keep in mind that the emitting and receiving unit require special electronics modules.

- Emitting unit - electronics module MP60EE.T**
- Receiving unit - electronics module MP60EE.R**

4.3 Mounting steps

To exchange the electronics module, proceed as follows:

- 1 Switch off power supply
- 2 Unscrew the housing cover
- 3 Lift the terminal block with a small screwdriver and pull it out.
- 4 Loosen the two screws with a screw driver (Torx size T10 or slot 4)

Electronics module - emitting unit MP60EE.T**

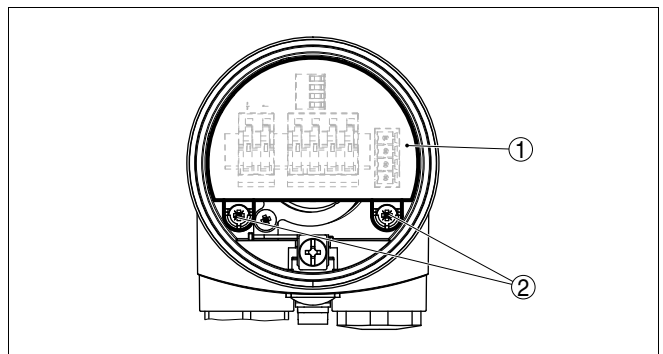

Fig. 1: Loosening the holding screws

- 1 Electronics module
- 2 Screws (2 pcs.)
- 5 Pull out the old electronics module
- 6 Compare the new electronics module with the old one. The type label of the electronics module must correspond to that of the old electronics module. This applies particularly to instruments used in hazardous areas.

- 7 Insert the electronics module carefully. Make sure that the plug is in the correct position.



Information:

Make sure that the housing is not rotated during the electronics exchange. Otherwise the plug may be in a different position later.

- 8 Insert the two hold screws and tighten them
 - 9 Insert the terminal block again. You must hear it snap in.
 - 10 Screw the housing cover on
- The electronics exchange is now finished.



As a rule, an exchange of electronics must be documented internally when Ex applications are involved.

Electronics module - receiving unit MP60EE.R**

To exchange the electronics module, proceed as follows:

- 1 Switch off power supply
- 2 Unscrew the housing cover
- 3 Lift the terminal blocks with a small screwdriver and pull them out.
- 4 Loosen the two screws with a screw driver (Torx size T10 or slot 4)

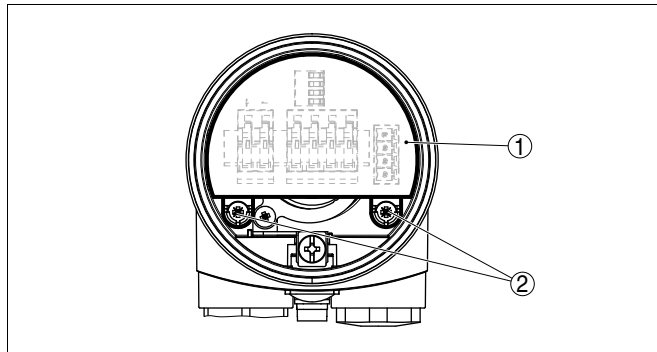

Fig. 2: Loosening the holding screws

- 1 Electronics module
 - 2 Screws (2 pcs.)
- 5 Pull out the old electronics module
 - 6 Compare the new electronics module with the old one. The type label of the electronics module must correspond to that of the old electronics module. This applies particularly to instruments used in hazardous areas.
 - 7 Insert the electronics module carefully. Make sure that the plug is in the correct position.

**Information:**

Make sure that the housing is not rotated during the electronics exchange. Otherwise the plug may be in a different position later.

- 8 Insert the two hold screws and tighten them
 - 9 Insert the terminal blocks again. You must hear them snap in.
 - 10 Carry out the adjustment according to the operating instructions of the sensor
 - 11 Screw the housing cover on
- The electronics exchange is now finished.



As a rule, an exchange of electronics must be documented internally when Ex applications are involved.

5 Setup

5.1 Setup

Setup

After having exchanged the electronics module, the complete setup must be carried out.

The adjustment should be carried out according to the description in the operating instructions manual.

6 Maintain

6.1 How to proceed in case of repair

If a repair is necessary, please proceed as follows:

You can download a return form (23 KB) from our Internet homepage www.vega.com under: "*Downloads - Forms and certificates - Repair form*".

By doing this you help us carry out the repair quickly and without having to call back for needed information.

- Print and fill out one form per instrument
- Clean the instrument and pack it damage-proof
- Attach the completed form and, if need be, also a safety data sheet outside on the packaging
- Please ask the agency serving you for the address of your return shipment. You can find the competent agency on our website www.vega.com.

7 Dismounting

7.1 Dismounting steps

**Warning:**

Before dismounting, be aware of dangerous process conditions such as e.g. pressure in the vessel, high temperatures, corrosive or toxic products etc.

Take note of chapters "*Mounting*" and "*Connecting to power supply*" and carry out the listed steps in reverse order.

7.2 Disposal

The instrument consists of materials which can be recycled by specialised recycling companies. We use recyclable materials and have designed the electronics to be easily separable.

WEEE directive 2002/96/EG

This instrument is not subject to the WEEE directive 2002/96/EG and the respective national laws. Pass the instrument directly on to a specialised recycling company and do not use the municipal collecting points. These may be used only for privately used products according to the WEEE directive.

Correct disposal avoids negative effects to persons and environment and ensures recycling of useful raw materials.

Materials: see chapter "*Technical data*"

If you have no way to dispose of the old instrument properly, please contact us about return and disposal.

8 Supplement

8.1 Technical data

Technical data

are stated in the operating instructions manual of the respective sensor.



Printing date:

VEGA Grieshaber KG
Am Hohenstein 113
77761 Schiltach
Germany
Phone +49 7836 50-0
Fax +49 7836 50-201
E-mail: info@de.vega.com
www.vega.com



All statements concerning scope of delivery, application, practical use and operating conditions of the sensors and processing systems correspond to the information available at the time of printing.

© VEGA Grieshaber KG, Schiltach/Germany 2010